

# *Digital Videocassette Recorder*

Operating Instructions-

Mode d'emploi \_\_\_\_\_

GB

FR



## **DSR-11**

## WARNING

To prevent fire or shock hazard, do not expose the unit to rain or moisture.



**CAUTION**  
RISK OF ELECTRIC SHOCK  
DO NOT OPEN



CAUTION TO REDUCE THE RISK OF ELECTRIC SHOCK,  
DO NOT REMOVE COVER (OR BACK)  
NO USER SERVICEABLE PARTS INSIDE  
REFER SERVICING TO QUALIFIED SERVICE PERSONNEL



This symbol is intended to alert the user to the presence of uninsulated "dangerous voltage" within the product's enclosure that may be of sufficient magnitude to constitute a risk of electric shock to persons



This symbol is intended to alert the user to the presence of important operating and maintenance (servicing) instructions in the literature accompanying the appliance

The AC adaptor must be changed only at qualified service shop

The nameplate of the AC adaptor is located on its bottom

### For customers in Europe

This product with the CE marking complies with both the EMC Directive (89/336/EEC) and the Low Voltage Directive (73/23/EEC) issued by the Commission of the European Community

Compliance with these directives implies conformity to the following European standards

- EN60065 Product Safety (supplied AC adaptor)
- EN55103-1 Electromagnetic Interference (Emission)
- EN55103-2 Electromagnetic Susceptibility (Immunity)

This product is intended for use in the following Electromagnetic Environments)

E1 (residential), E2 (commercial and light industrial), E3 (urban outdoors) and E4 (controlled EMC environment, ex TV studio)

### For the customers in the Netherlands

#### Voor de klanten in Nederland



BI) dit product zijn batterijen geleverd Wanneer deze leeg zijn, moet u ze met weggooien maar inleveren als KCA

## Owner's record

The model number is located at the rear and front of the unit and the serial number on the rear Record the serial number in the space provided below Refer to these numbers whenever you call upon your Sony dealer regarding this product

Model No DSR-11 Serial No. \_\_\_\_\_

### For customers in the U.S.A.

*If you have any questions about this product, you may call: Sony's Business Information Center (BIC) at 1-800-686-SONY (7669)*

**or Write to: Sony Customer Information Services Center  
6900-29 Daniels Parkway, PMB 330 Fort  
Myers, Florida 33912**

### Declaration of Conformity

Trade Name.	SONY
Model	DSR-11
Responsible Party:	Sony Electronics Inc
Address.	1 Sony Drive, Park Ridge, NJ 07656 U S A
Telephone Number	201-930-6972

This device complies with Part 15 of the FCC Rules Operation is subject to the following two conditions (1) This device may not cause harmful interference, and (2) this device must accept any interference received, including interference that may cause undesired operation

## CAUTION

You are cautioned that any changes or modifications not expressly approved in this manual could void your authority to operate this equipment.

### Note

This equipment has been tested and found to comply with the limits for a Class B digital device, pursuant to Part 15 of the FCC Rules. These limits are designed to provide reasonable protection against harmful interference in a residential installation. This equipment generates, uses, and can radiate radio frequency energy and, if not installed and used in accordance with the instructions, may cause harmful interference to radio communications. However, there is no guarantee that interference will not occur in a particular installation. If this equipment does cause harmful interference to radio or television reception, which can be determined by turning the equipment off and on, the user is encouraged to try to correct the interference by one or more of the following measures:

- Reorient or relocate the receiving antenna.
- Increase the separation between the equipment and receiver.
- Connect the equipment into an outlet on a circuit different from that to which the receiver is connected.
- Consult the dealer or an experienced radio/TV technician for help.

## For customers in the U.S.A. and CANADA

## CAUTION

TO PREVENT ELECTRIC SHOCK, MATCH WIDE BLADE OF PLUG TO WIDE SLOT, FULLY INSERT.

## Caution

Television programs, films, video tapes and other materials may be copyrighted. Unauthorized recording of such material may be contrary to the provisions of the copyright laws. Also, use of this recorder with cable television transmission may require authorization from the cable television transmission and/or program owner.

## Precautions

- Do not damage the power cord and AC adaptor.
- Use only the supplied power cord and supplied AC adaptor.
- Do not use the unit in an environment that is subject to excessive soot, steam, humidity or dust.

You can use this equipment in any country or area with the AC power adaptor supplied with this unit within 100 V to 240 V AC, 50/60 Hz.

Use a commercially available AC plug adaptor [a], if necessary, depending on the design of the wall outlet [b].

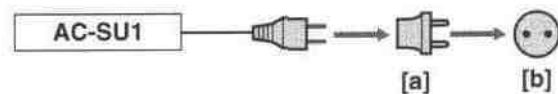

The AC adaptor is not intended to be serviced. Should the product cease to function in its intended manner, it should be returned to the manufacturer or be discarded.

## On installing

The unit is equipped with ventilation holes on the rear. Do not block or place anything near these holes, or internal heat build-up may occur, causing damage to the unit.

## On repacking and shipping

Save the original shipping carton and packing material; they will come in handy if you ever have to ship your unit. For maximum protection, repack your unit as it was originally packed at the factory, and take care not to impart violent shocks in transit.

# Table of Contents

## Chapter 1

### Overview

<b>Features .....</b>	<b>6</b>
DVCAM Format.....	6
Other Features .....	7
<b>Location and Function of Parts .....</b>	
Front Panel .....	8
Rear Panel .....	11
Supplied Remote Commander .....	13

## Chapter 2

### Playback and Recording

<b>Notes on Video Cassettes .....</b>	<b>15</b>
<b>Preparations .....</b>	<b>17</b>
Power Preparations.....	17
Inserting/Ejecting Cassettes .....	17
Notes on Recording/Playback .....	19
<b>Playback .....</b>	<b>20</b>
Connections for Playback.....	20
Settings for Playback.....	23
Playback Procedure .....	24
Playback Functions .....	25
<b>Recording .....</b>	<b>34</b>
Connections for Recording.....	34
Settings for Recording .....	37
Recording Procedure .....	39
<b>Installing the Unit Vertically .....</b>	<b>40</b>

## Chapter 3

### Adjusting and Setting Through Menus

<b>Operating the Menus .....</b>	<b>41</b>
Menu Organization .....	42
Menu Contents .....	43

## **Chapter 4**

### **Maintenance**

Troubleshooting.....	50
Alarm Messages .....	51
Notes on Use .....	52

## **Appendix**

Compatibility of DVCAM and DV Format.....	55
Specifications.....	58
Glossary.....	60
Index.....	61

# Overview

## Features

The DSR-11 is a 1/4-inch digital video cassette recorder that uses the DVCAM™ digital recording format. This system achieves stable, superb picture quality by digitally processing video signals that are separated into color difference signals and luminance signals (component video).

With a compact, lightweight and space-saving case, the unit can be installed vertically and is equipped with an analog interface as well as a digital interface enabling connection to a digital device such as a computer.

The DSR-11's main features are described below.

### **DVCAM Format**

DVCAM is based on the consumer DV format, which uses the 4:1:1 component digital format (NTSC) or the 4:2:0 format (PAL), and provides a 1/4-inch digital recording format for professional use.

### **High picture quality, high stability**

Video signals are separated into color difference signals and luminance signals, which are encoded and compressed to one-fifth size before being recorded to ensure stable and superb picture quality.

Because the recording is digital, multi-generation digital dubbing can be performed with virtually no deterioration of quality.

### **Wide track pitch**

The recording track pitch is 15 um, fully 50 percent wider than the DV format's 10-um track pitch. Thanks to this feature, the DVCAM format sufficiently meets the reliability and precision requirements of professional editing.

### **High-quality PCM digital audio**

PCM recording makes for a wide dynamic range and a high signal-to-noise ratio, thereby enhancing sound quality.

There are two recording modes: 2-channel mode (48-kHz sampling and 16-bit linear code), which offers sound quality equivalent to the DAT (Digital Audio Tape) format, or 4-channel mode (32-kHz sampling and 12-bit nonlinear code).

### **DV format compatibility**

A DV cassette recorded on a DV-format VCR can be played back on the unit (SP mode only). The unit can also record in DV format (SP mode only). (Recording/playing back an image in LP mode is not available.)

## NTSC/PAL systems compatible

The unit is compatible with NTSC and PAL systems. When inputting the signals to the DV IN/OUT connector or playing back a tape, the color system of signals is detected automatically. The color system select switch on the unit allows input of analog video signals in either color system. This compatibility allows you to record (download) or play back (upload) both NTSC and PAL formatted signals with your VCR, computer, or other equipment. However, the unit cannot convert the color system of the signals.

## Choice of two cassette sizes

The unit can use both standard-size and mini-size DVCAM or DV cassettes.

- According to cassette size, the position of the reel drive plate changes automatically.
- The maximum recording/playback times are 184 minutes for standard size cassettes and 40 minutes for mini-size cassettes (DVCAM format).

## Remote control

The unit can be operated by remote control from a CONTROL-S system remote control unit, the DSRM-20 (not supplied).

## High-speed search function

When you use an editing controller or the optional remote control unit (DSRM-20), the unit has a picture search function that allows you to view color picture at playback speeds up to 14 times (NTSC) or up to 17 times (PAL) normal speed in forward and reverse directions. You can also search frame-by-frame in jog mode.

You can also hear playback audio.

## Digital slow playback

The unit has a frame memory function that allows smooth, slow playback. This is available only at +1/3-time speed and -1/3-time speed.

## Jog audio function

If you use the optional remote control unit DSRM-20, audio can be monitored at various playback speeds when in jog mode.

## Other Features

### Compact and can be installed vertically

The unit is compact and can be installed vertically. With non-linear editing system, you can save space by installing it vertically beside your computer.

### Menu system for functionality and operation settings

The unit provides a menu system to make its various functions easier to use and set up.

### Superimposition function

Time code, operation mode indications, menus, error messages, and other text data can be superimposed and output in analog video signals.

### Easy maintenance functions

- **Self-diagnostics/alarm functions:** The system automatically detects an invalid operation, an invalid connection or a malfunction, and outputs a description, a cause and a recovery method as a message superimposed on analog video signals.
- **Digital hours meter:** A digital hours meter counts four types of time data—operating time, drum rotation time, tape running time, and tape threading/unthreading. The digital hours data is displayed in the menu.

**DVCAM**, **DV**, **MiniDV** and **Hi8** are trademarks of Sony Corporation.

# Location and Function of Parts

## Front Panel

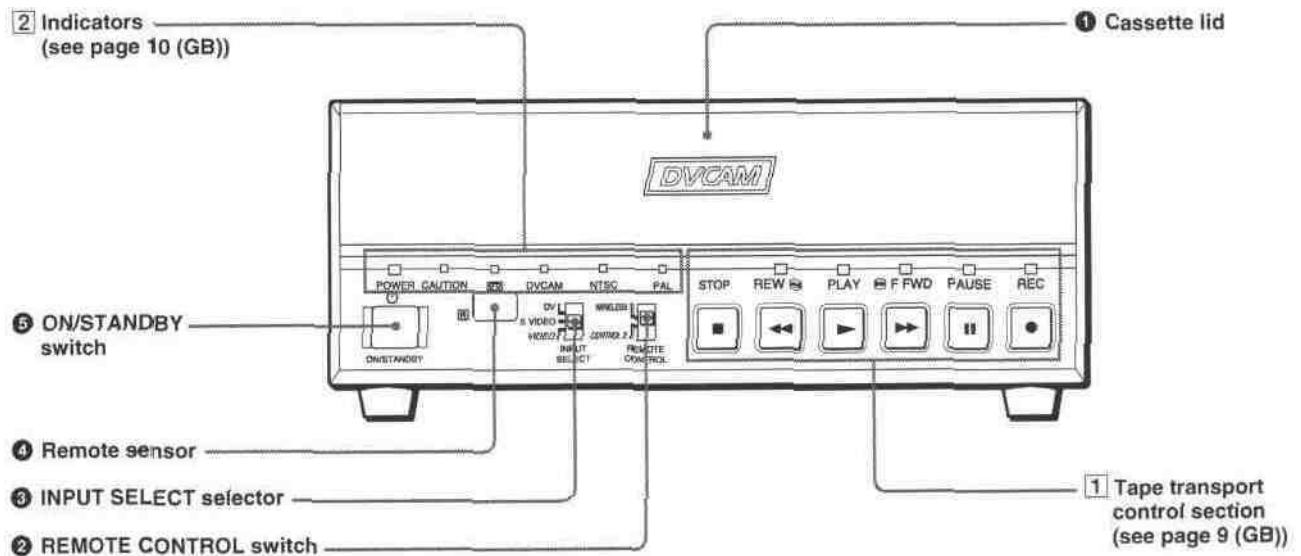

### 1 Cassette lid

To insert/eject a cassette, open the lid.  
*For details of usable cassettes, see "Notes on Video Cassettes" on page 15 (GB).*

### 2 REMOTE CONTROL switch

Selects whether the unit is operated from the Remote Commander or from an optional remote control unit.

**WIRELESS:** The unit is operated from the Remote Commander.

**CONTROL S:** The unit is operated from a remote control unit (the DSRM-20, not supplied), connected to the CONTROL S jack on the rear panel.

#### Note

You can operate this unit from its front panel regardless of this switch setting.

### 3 INPUT SELECT selector

You can select DV, S VIDEO, or VIDEO to input the signals.

**DV:** Signal input from the DV IN/OUT connector

**S VIDEO:** Signal input from the S VIDEO connector on INPUT jacks

**VIDEO:** Signal input from the VIDEO jack on INPUT jacks

#### Note

Do not change the selector setting during recording. Otherwise, noise is output to the picture and sound and that portion will not be recorded properly.

### 4 Remote sensor

### 5 ON/STANDBY switch



## [1] Tape transport control section

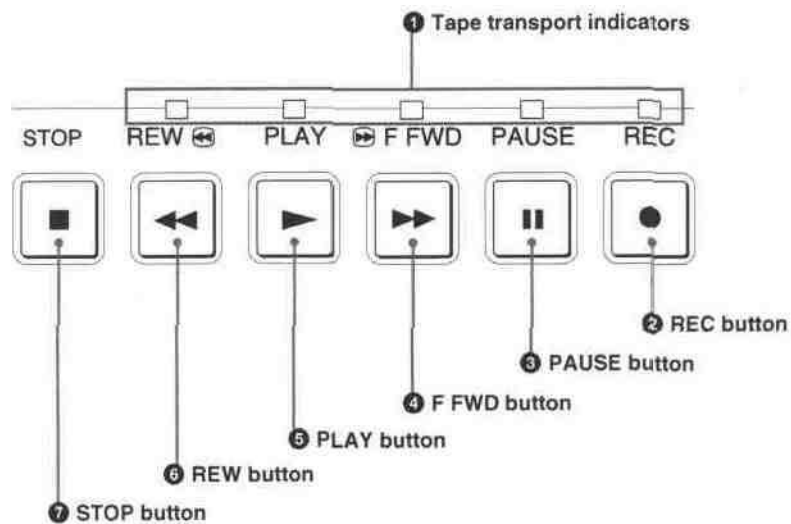

### 1 Tape transport indicators

### 2 REC (record) button

When you press the PLAY button while holding down this button, the indicator lights and recording begins. To set the unit to recording pause mode, press the PAUSE and PLAY buttons while holding down this button. If you press only this button when the unit is in the stop mode and the DV IN TC on the OTHERS menu is set to EXTERNAL, the REC indicator lights and you can also check the EE signals for time code. After checking them, press the STOP button.

For details on the OTHERS menu, see "OTHERS menu" on page 49 .

### Notes

- The unit cannot record in the LP mode of the consumer DV format. Only recording in the SP mode is available.
- To set the unit to recording pause mode with the remote control unit (DSRM-20, not supplied), press the PAUSE button while holding down the PLAY button to set the unit to the playback pause mode, then press the REC button on the DSRM-20.

### 3 PAUSE button

Press this button to set the unit to pause mode while recording or playing. Pressing this button again

resumes the operation. The indicator lights when the unit is in pause mode.

### 4 F FWD (fast forward) button

When you press this button, the indicator lights and the tape is fast forwarded. During fast forward, the picture does not appear on the monitor (you can see the picture as it is seen in the EE mode" during fast forward).

To locate a scene while monitoring the picture, keep pressing this button during fast forward, playback or in playback pause mode (picture search).

You can change the tape transport mode in FF/REW SPD on the VTR SET menu.

For details on the VTR SET menu, see "VTR SET menu" on page 43 .

### Note

If you set the FF/REW SPD on the VTR SET menu to SHUTTLEMAX, you can display the picture while fast-forwarding the tape.

### 5 PLAY button

When you press this button, the indicator lights and playback begins.

If you press this button while holding down the REW button during stop, the tape is rewound to its beginning and starts playing automatically (during rewind, the REW indicator lights and the PLAY indicator flashes).

### 1) EE mode

"EE" stands for "Electric to Electric". In this EE mode, the video and audio signals that are input to the VCR'S recording circuitry do not pass through any magnetic

conversion circuits but instead are output via electric circuits only. This mode is used to check the input signals and adjust input levels. The pictures output in EE mode are referred to as; FF nicturps

# Location and Function of Parts

## Notes

- When the unit is playing back a part of the tape where the recording format has been changed between the DVCAM format and the DV format, the picture and sound may be distorted.
- The unit cannot play back a tape recorded in the LP mode of the consumer DV format.

## 6 REW (rewind) button

When you press this button, the indicator lights and the tape starts rewinding. During rewind, the picture does not appear on the monitor (you can see the picture as it is seen in the EE mode during rewind).

To locate a scene while monitoring the picture, keep pressing this button during rewind, playback or in playback pause mode (picture search).

If you press the PLAY button while holding down this

button during stop, the tape is rewound to its beginning and starts playing automatically (during rewind, the REW indicator lights and the PLAY indicator flashes). You can change the tape transport mode in FF/REW SPD on the VTR SET menu.

*For details on the VTR SET menu, see "VTR SET menu" on page 43*

## Note

If you set the FF/REW SPD on the VTR SET menu to SHUTTLEMAX, you can display the picture while rewinding the tape.

## 7 STOP button

Press this button to stop the current tape transport operation.

## [2] Indicators

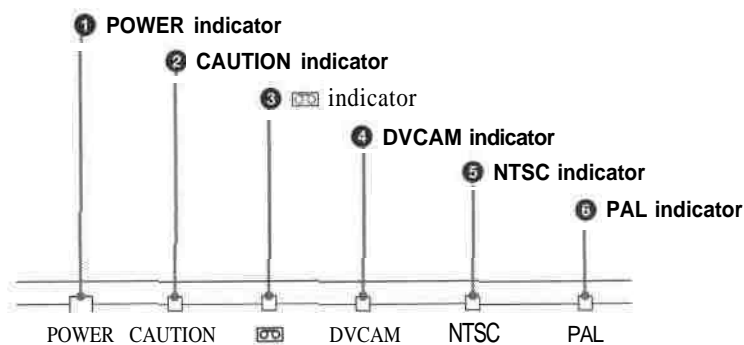

### 1 POWER indicator

Lights in green when the power of this unit is on and lights in red when the unit is in the standby mode.

### 2 CAUTION indicator

Flashes when an error occurs.

*For details on cautions, see "Alarm Messages" on page 51*

### 3 (cassette) indicator

Lights when a digital video cassette is loaded. Even if the unit is in the standby mode, the indicator lights as long as the cassette is inside of the unit. While the cassette is being ejected, the indicator flashes.

### 4 DVCAM indicator

Lights when the unit is playing back a tape recorded in DVCAM format.

When the REC MODE on the VTR SET menu is set to DVCAM, this indicator also lights during recording or in the EE mode.

*For details on the VTR SET menu, see "VTR SET menu" on page 43 (GB).*

### 5 NTSC indicator

Lights when:

- the unit is in the EE mode, analog video signals are input and the NTSC/PAL select switch is set to NTSC.
- the unit is in the EE mode and NTSC formatted video signals are input from the DV IN/OUT connector.
- a tape that has NTSC formatted video signals is being played back.

### 6 PAL indicator

Lights when:

- the unit is in the EE mode, analog video signals are input and the NTSC/PAL select switch is set to PAL.
- the unit is in the EE mode and PAL formatted video signals are input from the DV IN/OUT connector.
- a tape that has PAL formatted video signals is being played back.

## Rear Panel

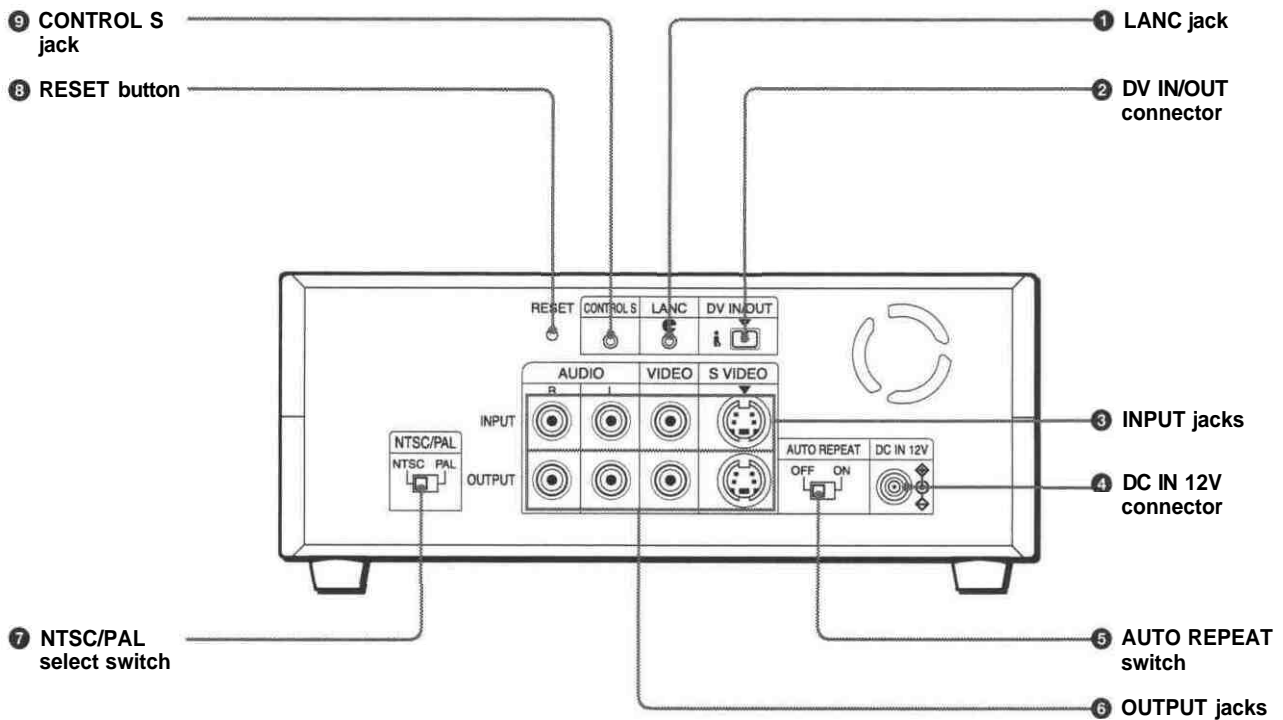

**1**  
Connects to other video devices that have a LANC jack. You can operate the unit from other video devices.

### Notes

- You cannot operate the ejection of a cassette from a device connected to the LANC jack.
- The LANC jack on the unit has only LANC-S functions. The unit has no LANC-M functions.

### **2 DV IN/OUT connector (4-pin)**

Used to input/output a digital signal that complies with the i.LINK standard (Recommended cable: VMC-IL4415(A), VMC-IL4615(A)). Use when an external device which you want to connect to the unit has a DV jack. If you connect the unit and the other device using DV jacks, you can minimize deterioration of picture quality during recording, dubbing or capturing still pictures into a personal computer by digital processing. For details, refer to the instruction manual of the equipment you use.

### Note

i.LINK and the i.LINK logo “i” are trademarks and indicate that this product is in agreement with IEEE 1394-1995 specifications and their revisions.

### **3 INPUT jacks**

Used to input analog video and audio signals. To connect a VCR equipped with S-video output, use the S VIDEO connector on the unit.

### **4 DC IN 12V connector**

### **5 AUTO REPEAT switch**

Used to repeat the playback of all or a part of the tape. For details on the auto repeat function, see “Auto Repeat” on page 32 .

## Location and Function of Parts

### 6 OUTPUT jacks

Used to output analog video and audio signals. To connect a VCR equipped with S-video input, use the S VIDEO connector on the unit.

#### Notes

- Various text data are superimposed and output from the VIDEO jack or the S VIDEO connector on the OUTPUT jacks. If you want to output video signals without text data, carry out the following operations.
  - Set TITLE DISP and LABEL DISP on the CM SET menu to OFF.
- Depending on the displayed items, press the MENU, DATA CODE, DISPLAY or SEARCH SELECT button on the Remote Commander to clear the text data on the monitor screen.

*For details on text data, see "Displaying data recorded on a tape" on page 25 and "Displaying various data" on page 26.*

*For details on the CM SET menu, see "CM SET menu" on page 46.*

- When the unit is in the EE mode (when the input signal is output as an analog signal), the subcarrier of the color signal is not synchronized with the horizontal sync signal. The color of the picture or the horizontal sync signal may be distorted depending on the type of monitor connected to the unit.

### 7 NTSC/PAL select switch

Used to switch the color system of signals that will be recorded on the unit when you use analog input.

To change the switch setting, turn off the power of the unit first, then use the tip of a ball-point pen or similar tool to slide this switch.

Before inputting NTSC or PAL formatted analog video signals, set this switch to appropriate position according to the color system of it.

#### Notes

- If the color system of the input signals is different from that of the switch setting, both picture and sound will be muted.
- When inputting signals to the DV IN/OUT connector or during playback, this switch setting is invalid. The unit detects the color system of the signals automatically.

- When the switch is set to PAL, the unit works as a PAL model. Therefore the time code generated by the unit while recording in the DVCAM format turns to the non-drop frame mode. Even if an NTSC formatted signal is input from the DV IN/OUT connector, the time code generated by the unit is non-drop frame mode as long as the switch is set to PAL, regardless of the TC FORMAT setting on the OTHERS menu. If you intend to set the unit to generate the time code in the drop frame mode, set the switch to NTSC.
- The color system of the signals output from the unit is the one recorded on the tape being played back. The unit cannot convert the color system of signals of one system into that of the other. (For example: converting NTSC formatted signals into PAL formatted signals is not possible) Therefore, to view or record the signal output from the unit, you need a device compatible with the color system of the signals output from the unit.
- When the color system of playback signals is different from the one last used on the unit, playback picture and sound will be distorted and time code will be discontinuous for a short time at the beginning of the playback.
- If you play back a tape with both NTSC and PAL color system recordings, the following limitations apply.
  - At the point where the recorded signals format changes, the picture may be distorted or the audio noise may be output.
  - The tape transport control buttons may be disabled until the tape running is stabilized.
- Do not change the switch setting during recording.

### 8 RESET button

Press this button to initialize the internal clock and all menu items. Press this button with the tip of a ball-point pen or similar tool.

### 9 CONTROL S jack

Connects to a remote control unit (DSRM-20, not supplied) for controlling this unit.

#### Note

When using a CONTROL S-device, set the REMOTE CONTROL switch on the front panel to CONTROL S. Otherwise, you cannot operate the unit with CONTROL S-devices.

## Supplied Remote Commander

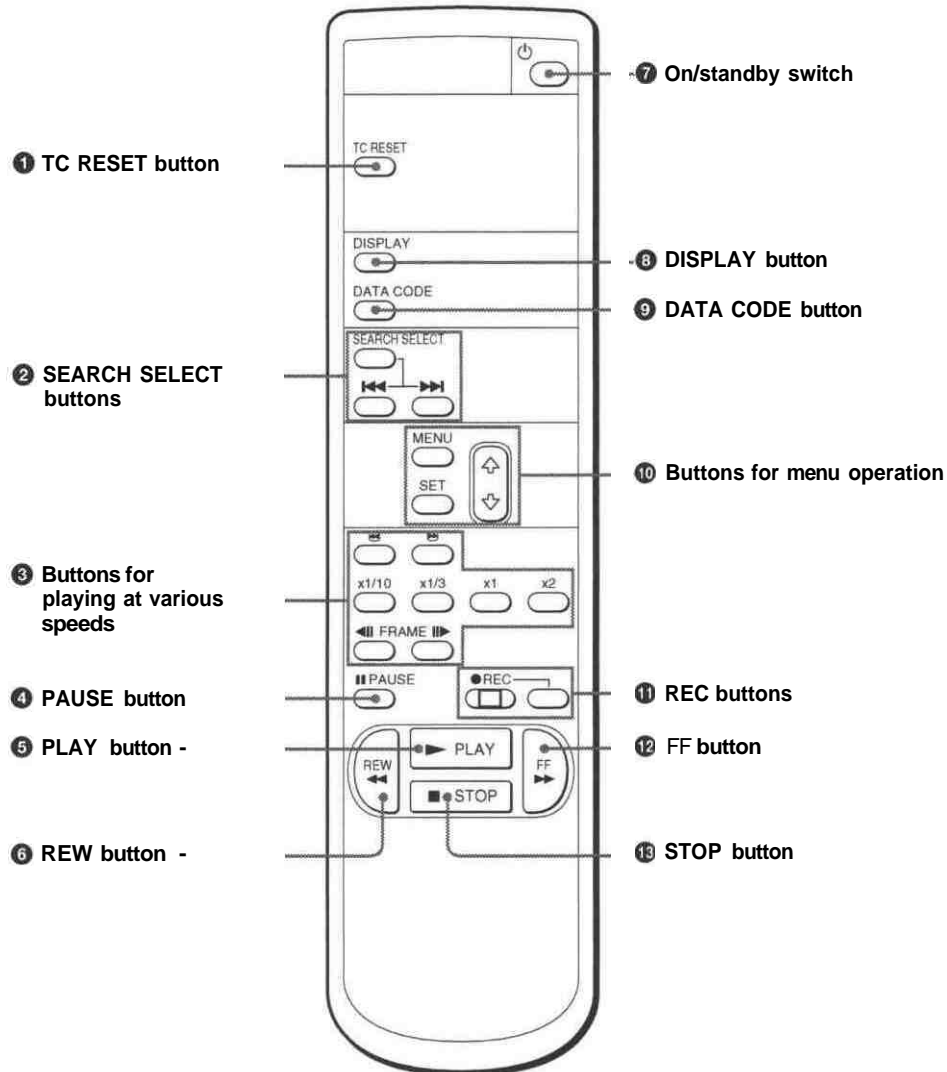

### 1 TC RESET button

Press this button to reset the time code to 00:00:00:00 during recording or in the recording pause mode.

#### Note

When the command mode of a Sony device / remote commander is set to VTR 4;

- if you press this button while pointing the Remote Commander toward a Sony device other than this unit, the HMS counter on that machine will be reset to zero.
- if you press a counter reset button on a Sony remote commander while pointing it toward this unit during recording or in the recording pause mode, the time code will be reset to zero.

### 2 SEARCH SELECT buttons

Press these buttons to search for scenes using the search function.

*For details on the search function, see "Searching using the search function" on page 29*

### 3 Buttons for playing at various speeds

You can play back a tape at normal speed or at a speed other than normal with these buttons.

*For details, see "Playing at various speeds" on page 28*

### 4 PAUSE button

### 5 PLAY button

# Location and Function of Parts

## 6 REW button

## 7 On/standby switch

## 8 DISPLAY button

Press this button to see indications, such as time code and tape remaining time, on the monitor screen.

*For details on displayed data, see "Displaying various data" on page 26*

## 9 DATA CODE button

Press this button to see the data codes (recording date/time, camera data) on the monitor screen.

*For details on data codes, see "Displaying data recorded on a tape" on page 25*

## 10 Buttons for menu operation

Press these buttons to operate the menu.

## 11 REC buttons

When you press these buttons at the same time, the REC and PLAY indicators light and recording begins.

## 12 FF button

## 13 STOP button

### Note

When using the Remote Commander, set the REMOTE CONTROL switch on the front panel to WIRELESS. Otherwise, you cannot operate this unit with the Remote Commander.

## Battery installation

1 Push and slide the lid to open.

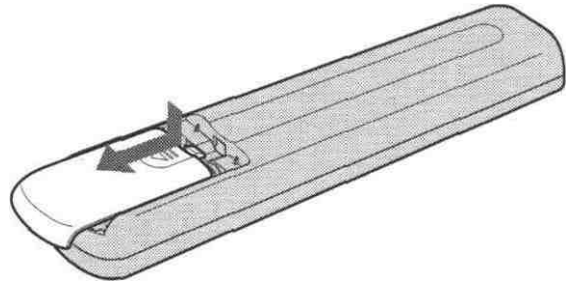

2 Install the two size AA (R6) batteries (supplied) with the correct polarity.

Be sure to install the battery from the  side.

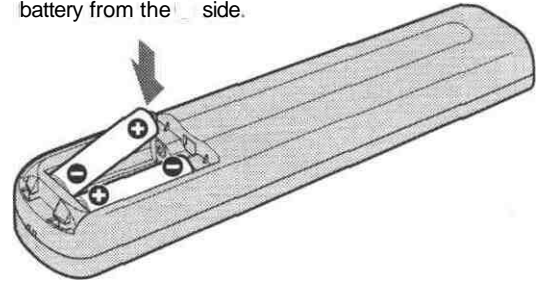

3 Replace the lid.

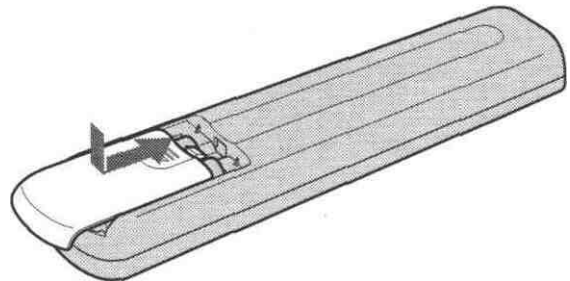

## Notes on batteries

- Make sure that the battery orientation is correct when inserting batteries.
- Do not mix an old battery with a new one, or mix different types of batteries.
- If you will not use the Remote Commander for a long time, remove the batteries to avoid damage from battery leakage. If batteries have leaked, remove them, wipe the battery compartment dry and replace the batteries with new ones.

# **Playback and Recording**

## Notes on Video Cassettes

### Usable cassettes

Use Standard-DVCAM cassettes or Mini-DVCAM cassettes with this unit. The PDV-184 can record programs for 184 minutes (DVCAM format) / 270 minutes (DV format) and the PDVM-40 can record for 40 minutes (DVCAM format) / 60 minutes (DV format).

You can get the highest quality pictures with this digital videocassette recorder using DVCAM cassettes. You may not be able to get as good quality with other cassettes. We recommend using DVCAM cassettes so that you can record your one-time events in the highest quality.

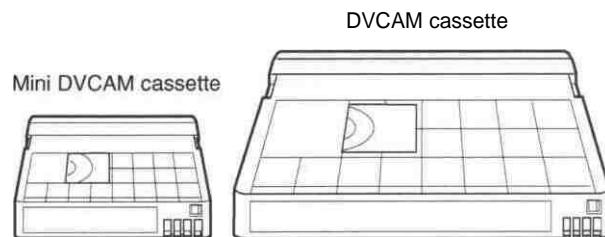

# Notes on Video Cassettes

## Cassette memory

Cassette memory is an optional feature that is mounted on some Standard DVCAM/DV cassettes and Mini DVCAM/Mini DV cassettes. When you record a program, the recording date and time, and the programs' position on the tape are stored in the cassette memory so that you can quickly locate the program later on. CPHGK indicates that you can use the cassettes to store up to 16 kbits of data. On this unit, you can use cassettes on which up to 16 kbits of data can be stored.

## To save a recording

To prevent accidental erasure of a recording, slide the REC/SAVE switch on the cassette so that the red portion becomes visible. To record on a tape, slide the switch so that the red portion is hidden.

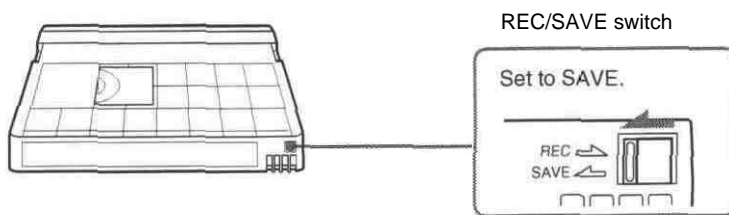

## Checking the tape for slack

Using a paper clip or a similar object, turn the reel gently in the direction shown by the arrow. If the reel does not move, there is no slack.

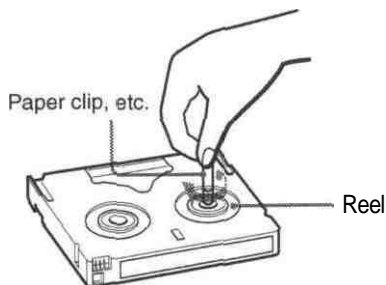



# Preparations

## Power Preparations

Connect the power cord (supplied) to the AC adaptor (AC-SU1, supplied) and connect the AC adaptor to the DC IN 12V connector on the unit. Then, connect the power plug to the wall outlet.

When you undo these connections, be sure to disconnect the power cord from the wall outlet first.

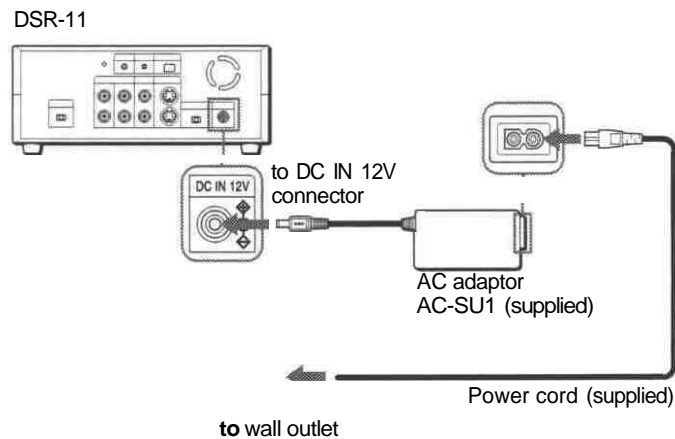

## Inserting/Ejecting Cassettes

### To insert a cassette

#### Notes

- Do not insert the cassette forcibly. The unit may be damaged.
- Do not eject/load the cassette in a place subject to light. Make sure to close the cassette lid when using the unit. The internal sensor of the unit may operate incorrectly if too much light finds its way into the unit.

- 1 With the unit powered on, confirm that the  indicator is off, then open the cassette lid.

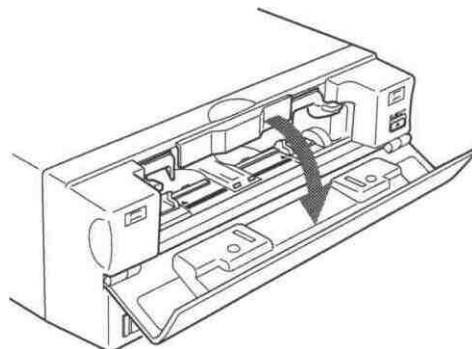

(Continued)

## Preparations

- 2 After checking the tape for slack, hold the cassette so that the tape **window is facing upward**, then insert it into the **unit**.

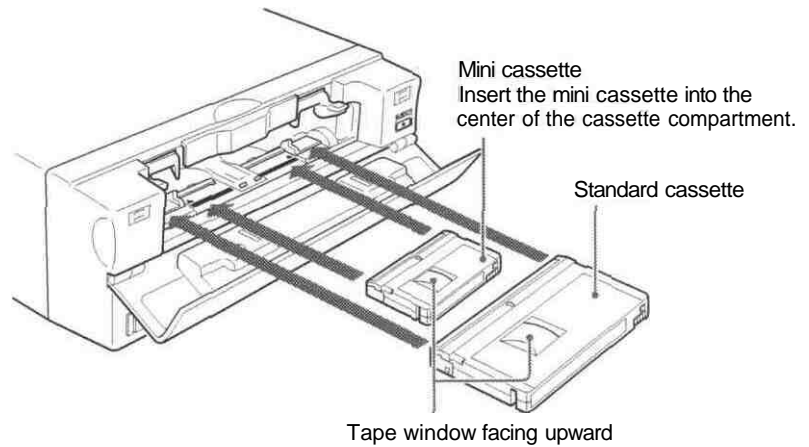

The cassette is automatically loaded into the unit.

- 3 Close the cassette lid.

### To eject the cassette

- 1 With the unit powered on, open the cassette lid. Press the EJECT button located at the right side of the cassette compartment.

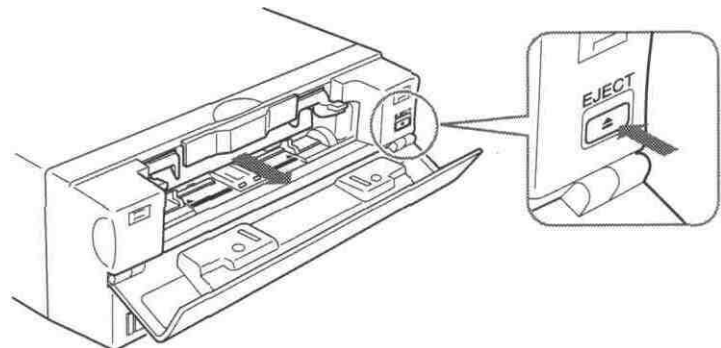

The cassette is unloaded and ejected.

- 2 Remove the cassette from the unit. Close the cassette lid.

---

## Notes on Recording/Playback

### **No compensation for contents of the recording**

Contents of the recording cannot be compensated for if recording or playback is not successful due to a malfunction of the unit, video tape, etc.

### **Copyright precautions**

#### **On recording**

You cannot record any software having copyright protection signals on this unit. If you start recording protected video and audio signals, a warning appears on the monitor screen and the unit stops recording.

#### **On playback**

If you play back a software having copyright protection signals **on this** unit, you may not be able to copy it onto other equipment.

### **Limitations caused by the difference in format**

The unit can record and play back tapes recorded in DVCAM format. It can also record and play back tapes recorded in DV format (SP mode). However, due to the difference in format, you may not be able to record or edit some tapes affected by recording conditions of the tape.

*For details, see "Compatibility of DVCAM and DV Format" on page 55 .*

This section describes the necessary connections, settings, and operations to perform playback on this unit. The same settings and operations apply whether you are using the unit for dubbing or as a stand-alone videocassette player.

## Connections for Playback

### To equipment with a DV jack

#### Connecting to a computer

The video and audio signals are sent to a computer with virtually no deterioration in quality, enabling high-quality uploading. The signal flow is automatically detected so you do not need to make separate connections for input and output.

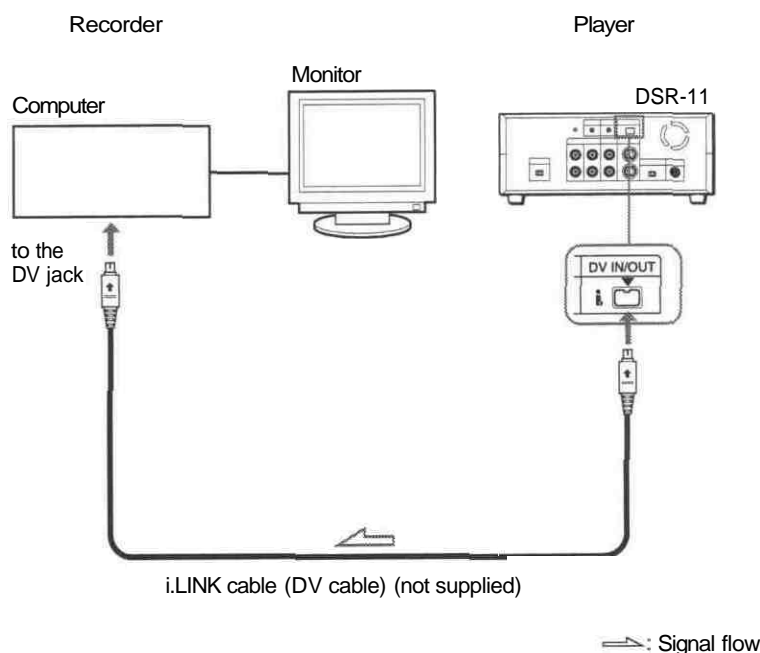

#### Notes

- Set DV EE OUT on the VTR SET menu to OFF.  
*For details on the VTR SET menu, see "VTR SET menu" on page 43 .*
- With the DV connection, data codes (recording date/time, camera data) recorded on the source tape are transmitted from this unit (player).

## Connecting to another VCR

The video and audio signals are sent to another VCR with virtually no deterioration in quality, enabling high-quality recording. The signal flow is automatically detected so you do not need to make separate connections for input and output.

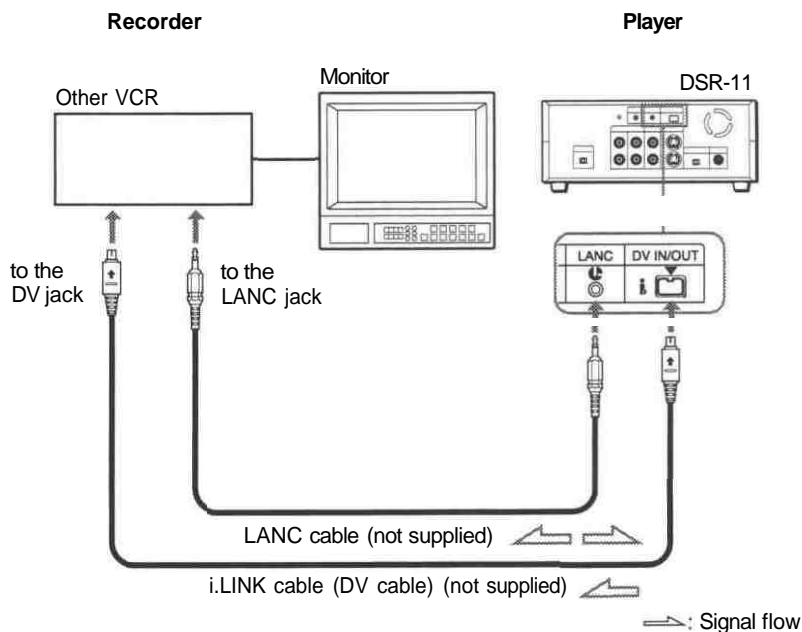

### Notes

- Set DV EE OUT on the VTR SET menu to OFF.  
*For details on the VTR SET menu, see "VTR SET menu" on page 43 .*
- With the DV connection, the sound is recorded in the same audio recording mode as that of the source tape. To record in a different audio recording mode from the source tape, use the analog connection instead.
- With the DV connection, data codes (recording date/time, camera data) recorded on the source tape are transmitted from this unit (player). As a result, when you play back a recorded tape on this unit and press the DATA CODE button on the Remote Commander, the same data codes recorded on the source tape are displayed on the monitor screen.
- As for the LANC connection, see "Notes for a LANC connection" on the next page.

## To video equipment without a DV jack

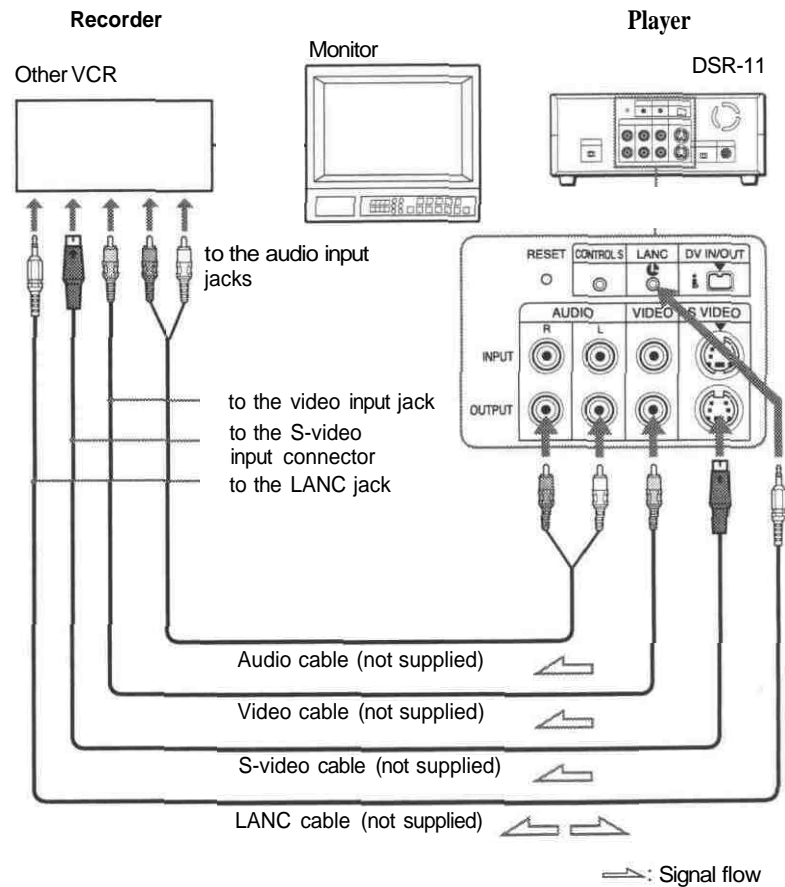

Connect either an S-video cable or a video cable as the cable for video signals.

### Notes

- When you connect the output jacks of the recorder to the input jacks of this unit, select the input correctly with an input select switch on the recorder to prevent a humming noise or distortion of the picture.
- Distorted signals (e.g., when played back at a speed other than normal) will not be recorded properly.

### Notes for a LANC connection

- The LANC connection transmits signals such as control signals, time code, time counter data, and status data.
- Jacks labeled CONTROL L have the same function as LANC jacks. Jacks labeled REMOTE may also have the same function.
- Set the LANC switch on the recorder to M. A device which does not have M / S switch cannot be used to control this unit.

## Settings for Playback

### Preparation on the player (this unit)

#### Note

Various text data are superimposed and output from the VIDEO jack or the S VIDEO connector on the OUTPUT jacks. If you want to record video signals without text data, carry out the following operations.

- Set TITLE DISP and LABEL DISP on the CM SET menu to OFF.
- Depending on the displayed items, press the MENU, DATA CODE, DISPLAY or SEARCH SELECT button on the Remote Commander to clear the text data on the monitor screen.

*For details on text data, see "Displaying data recorded on a tape" on page 25 and "Displaying various data" on page 26.*

*For details on the CM SET menu, see "CM SET menu" on page 46.*

**1** Power on the video monitor, then set the monitor's input switch according to the signals input from the recorder.

**2** Set up the recorder.

*For details, refer to the instruction manual of the recorder.*

**3** Power on this unit by pressing the ON/STANDBY switch on this unit.

**4** When you play back a tape recorded in 4-channel mode (Fs32k), adjust the balance between channel 1/2 and channel 3/4 with AUDIO MIX on the AUDIO SET menu.

*For details on the AUDIO SET menu, see "AUDIO SET menu" on page 44.*

#### Note

The AUDIO MIX on the AUDIO SET menu (audio balance adjustment) does not function on the source audio output through the DV IN/OUT connector.

## Playback Procedure

This section describes the procedures used to play back a tape and send signals to another VCR. For details on the procedures required when using a computer as a recorder, refer to the instruction manual of your computer or the user's manuals of the software installed in it.

- 1** After checking the tape for slack and confirming that the  indicator is off, hold the cassette so that the tape window is facing upward, then insert it into this unit.

*For details on checking the tape for slack, see "Notes on Video Cassettes" on page 15 .*

### Note

Do not insert the cassette forcibly. The unit may be damaged.

The cassette is automatically loaded into the unit.

- 2** Press the PLAY button.

This unit starts playback.

### To stop playback

Press the STOP button on the unit.

### To pause playback

Press the PAUSE button on the unit.

### Notes

- When this unit is playing back a part of the tape where the recording format has been changed between the DVCAM format and the DV format, the picture and sound may be distorted.
- This unit cannot play back a tape recorded in the LP mode of the consumer DV format.



## Playback Functions

### Displaying data recorded on a tape

If you record on a tape using a Sony digital camcorder (DSR-200/200P, 200A/200AP, PD100/PD100P, PD100A/PD100AP, PD150/PD150P, 250/250P, etc.), data codes (the shutter speed, SteadyShot, program AE mode, white balance, iris, gain, date and time) can be recorded on the tape. You can check these data items during playback on this unit.

Press the DATA CODE button on the Remote Commander during playback.

Each time you press the DATA CODE button, the display changes as follows.

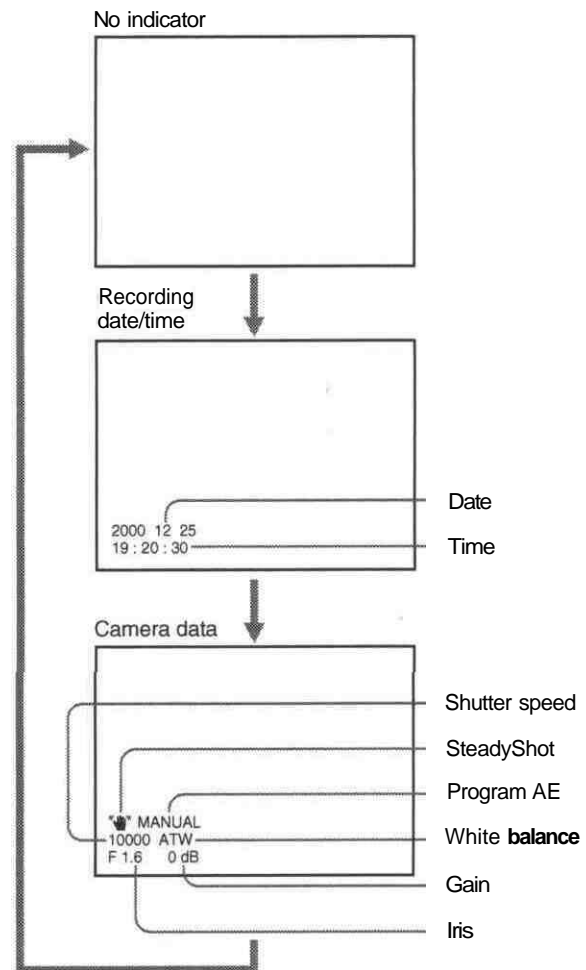

(Continued)

## Notes

- The data codes are also displayed by setting DATA CODE on the DISPLAY SET menu. You can change the displayed item in the same way as described above.

## Example

Menu setting : CAMERA

**Display** : camera data → no indicator → recording date/time → camera data

*For details on the DISPLAY SET menu, see "DISPLAY SET menu" on page 45*

- Camera data items show the settings of a tape recorded by a digital camcorder (DSR-200/200P, 200A/200AP, PD100/PD100P, PD100A/PD100AP, PD150/PD150P, 250/250P, etc.). This unit cannot record camera data.
- When the data codes were not recorded, "- -" appears instead.
- Some of the camera data items displayed on the monitor screen by this unit are different from those shown by the digital camcorder.

## Displaying various data

You can check various data items such as the time code, tape remaining time, etc. on the monitor screen. These data items are useful for normal recording/playback operation.

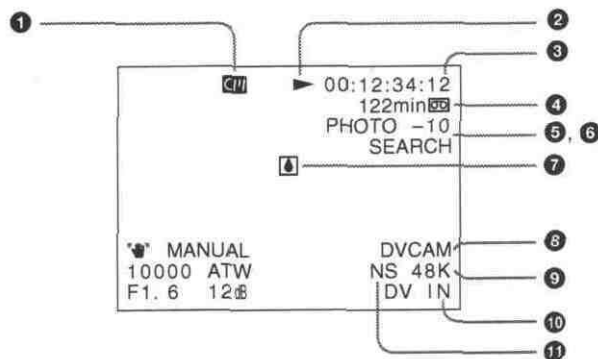

An item with \* is displayed when you press the DISPLAY button on the Remote Commander.

You can hide the item by pressing the DISPLAY button again.

### ① Cassette memory indicator\*

This is shown when a cassette with cassette memory has been loaded.

### ② Tape transport mode indicator\*

Displays the tape transport mode.

### ③ Time code indicator\*

- Displays the time code. In the drop frame mode (only for NTSC), a period is displayed between the minute and second. (Example: 00:12.58:00)
- Displays the diagnostics code numbers if the self-diagnostic function is enabled.

### ④ Tape remaining time indicator\*

If REMAIN on the DISPLAY SET menu has been set to ON, the remaining tape time is displayed.

#### Note

If the tape has been rewound to the beginning, this indicator will not show the tape time remaining when the tape is inserted into the unit. The remaining tape time is displayed after the tape runs for a while.

### ⑤ Search indicator

Displays the search mode when you search for scenes with the Remote Commander or the DSRM-20 (not supplied).

*For details on the search function, see "Searching using the search function" on page 29 .*

### ⑥ Index indicator\*

Displays the INDEX MARK when an index has been marked.

### ⑦ Caution indicators\*

Displays a caution.

*For details on cautions, see "Alarm Messages" on page 51 .*

### ⑧ DVCAM/DV indicator\*

In the EE and recording modes, displays the recording format selected in REC MODE on the VTR SET menu. During playback, displays the recording format recorded on the tape.

### ⑨ Audio mode indicator\*

In the EE and recording modes, displays the audio mode selected in AUDIO MODE on the AUDIO SET menu. During playback, displays the audio mode recorded on the tape. When inputting signals from the DV IN/OUT connector, displays the audio mode of signals input from the DV IN/OUT connector.

### ⑩ Input signal indicator\*

Displays the INPUT SELECT selector setting.

### ⑪ NS (Non Standard) audio mode indicator\*

This is shown when you play back a tape in the unlock audio mode or when the unlock mode signal has been input from the DV IN/OUT connector. Always this is shown when the REC MODE on the VTR SET menu has been set to DV SP and the unit is in the EE mode.

*For details on the unlock mode, see "Compatibility of DVCAM and DV Format" on page 55 .*

## Playing at various speeds

You can enjoy playback functions using the Remote Commander.

Playback options	Operation
Play at 1/10 of normal speed	Press × 1/10 during playback.
Play at 1/3 of normal speed	Press × 1/3 during playback.
Play at normal speed	Press × 1 during playback.
Play at twice the normal speed	Press × 2 during playback.
Play frame by frame	Press FRAME ◀   ▶ during pause. If you keep pressing one of these buttons, playback continues, frame by frame.

### To change playback direction

Press the FRAME ◀|||▶ buttons during playback at various speeds. To play back in the forward direction, press the ||▶ button; in the backward direction, press the ◀|| button.

### To hear the sound when playing at various speeds

If you want to hear the sound when playing at various speeds, set JOG AUDIO on the AUDIO SET menu to ON.

*For details on the AUDIO SET menu, see "AUDIO SET menu" on page 44 .*

#### Note

When the command mode of a Sony device / remote commander is set to VTR4;

- if you press the x 1/3 button while pointing the Remote Commander toward a Sony device other than this unit, the playback speed may turn to 1/5 of normal speed.
- if you press the x 1/5 button on a remote commander while pointing it toward this unit, the playback speed will turn to 1/3 of normal speed.



## Searching without cassette memory

When you use a tape without cassette memory, the unit searches in the order of the actual positions of the recordings, regardless of the setting of CM SEARCH on the CM SET menu.

When you use a tape with cassette memory, set CM SEARCH on the CM SET menu to OFF.

*For details on the CM SET menu, see "CM SET menu" on page 46*

### Note

The title search is not available in searching without cassette memory.

- 1 Press the SEARCH SELECT button on the Remote Commander to select the search type.

### When selecting INDEX SEARCH

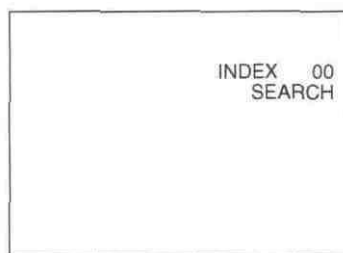

- 2 Press the **⏮** or **⏭** button repeatedly to locate the recording you want.

Each time you press the **⏮** or **⏭** button, the unit searches for the previous or next search point. When a search point is located, its number is indicated on the monitor screen.

The unit starts searching backwards or forwards until the number comes to zero, then plays back the recording. During Photo search, the unit turns to the playback pause mode.

## How signals are recorded

There are four different signal types, one for each search method; index, title, date and photo signals. They are recorded by the digital camcorder (DSR-200/200P, 200A/200AP, PD100/PD100P, PD100A/PD100AP, PD150/PD150P, 250/250P, etc.). However, the type of signal recorded and where it is recorded (on the tape or in the cassette memory) depends on whether the cassette has cassette memory or which type of video equipment is used for recording. Please note that if the signals for a certain search type are not recorded, you cannot do that type of search. For details on the signals used for a particular type of search, refer to the instruction manual of the recorder.

## When you record on this unit

Signals for	In cassette memory	On tape
Index search*	Yes	Yes
Title search	No	No
Date search	No	Yes
Photo search	No	No

\* The signals for Index search are recorded when you start recording in stop mode.

### Notes

- If you record another program over the beginning of the search signals, you will not be able to locate the original program.

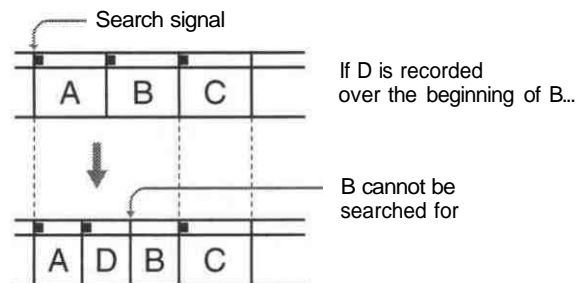

- You cannot add search signals after recording.  
To add signals only for Auto Repeat, start recording from the point you want to add them.
- When recording on this unit, signals for index search do not have information on the day of the week.
- Searching may not be done correctly if the signals were not recorded on a piece of Sony-brand digital video equipment.

### About the cassette memory

- A tape with **CM** mark has cassette memory. When using the 16 kbits cassette memory, you can store up to 135 search signals. (The number changes depending on the memory capacity of various tapes. It also changes depending on the data size combination of index, title, date, photo, and tape label data stored on a tape.) This unit is capable of storing and retrieving up to 16 kbits of information in cassette memory.
- To locate recordings that did not fit in the cassette memory, or to locate recordings in order of their position on the tape, set CM SEARCH on the CM SET menu to OFF. You can use the same procedure to search for a recording on a tape without cassette memory.

*For details on the CM SET menu, see "CM SET menu" on page 46 .*

### Note

The number of search signals that you can record is limited by the cassette memory space available when you start recording. When you use a previously recorded tape for repeated recordings, make more memory space available by erasing unwanted items using ITEM ERASE or ERASE ALL on the CM SET menu before you start recording.

# Playback

## Auto Repeat

This unit can repeat the playback of all or a part of the tape.

- 1 Set the AUTO REPEAT switch on the rear panel to ON.
- 2** Press the REW button. (If the tape is already rewound, press the PLAY button.)

The unit rewinds the tape to its beginning, and starts playback automatically. The unit repeats the playback from the beginning to the first index (if there is no signal for index search on the tape, to the next unrecorded portion; if there is no unrecorded portion, to the end of the tape).

### Auto Repeat using an external AC timer

If you connect an external AC timer (not supplied) to this unit, you can repeat playback automatically at the preset time.

- 1** Connect an external AC timer (not supplied) to this unit.

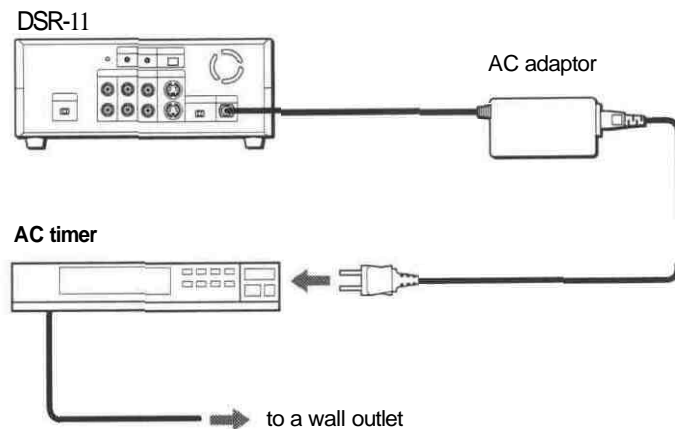

- 2** Set the AUTO REPEAT switch on the rear panel to ON.
- 3** Set the starting time on the external AC timer.

At the preset time, the power of this unit turns on, and after a few seconds (no more than 30), Auto Repeat playback starts automatically. The unit repeats the playback from the beginning to the first index (if there is no signal for index search on the tape, to the next unrecorded portion; if there is no unrecorded portion, to the end of the tape).



---

### **Notes**

- The unit cannot search for a signal for index search or an unrecorded portion within 20 seconds of the beginning of the playback.
- While a tape is running, be sure not to turn off the power by using an AC timer. The unit and the tape may be damaged. When turning off the power of the unit, make sure to press the STOP button on this unit first to stop the tape transport, then turn off the power.

### **To stop Auto Repeat**

Press the STOP button on this unit.

### **To release the Auto Repeat mode**

Set the AUTO REPEAT switch on the rear panel to OFF.

This section describes the necessary connections, settings and operations to perform recording on this unit. The same settings and operations apply whether you are using the unit for dubbing or as a stand-alone recorder.

## Connections for Recording

### To equipment with a DV jack

#### Connecting to a computer

The video and audio signals are sent from a computer with virtually no deterioration in quality, enabling high-quality downloading. The signal flow is automatically detected so you do not need to make separate connections for input and output.

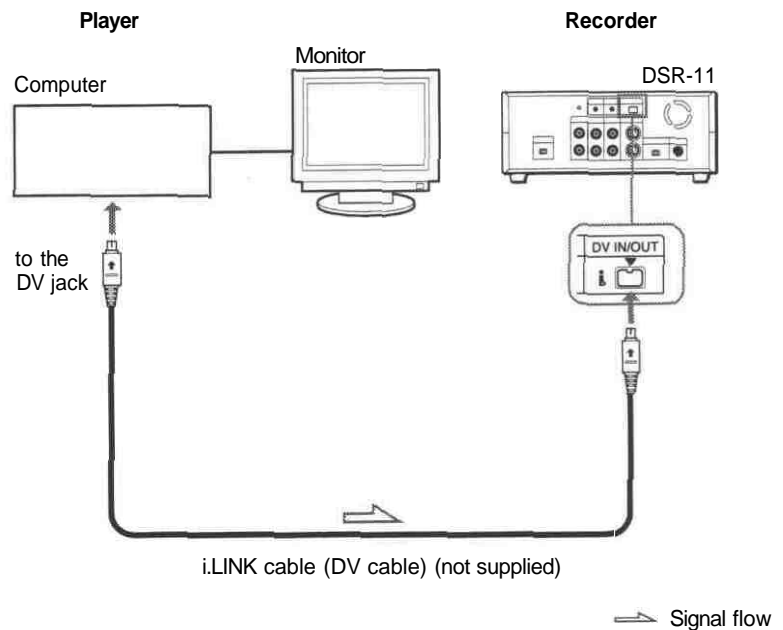

#### Notes

- With the DV connection, data codes (recording date/time, camera data) are transmitted from the computer (player). However, the contents of the cassette memory are not transmitted.
- If no picture appears via the DV jack, disconnect, then reconnect the i.LINK cable (DV cable).

## Connecting to another VCR

The video and audio signals are sent from another VCR with virtually no deterioration in quality, enabling high-quality recording. The signal flow is automatically detected so you do not need to make separate connections for input and output.

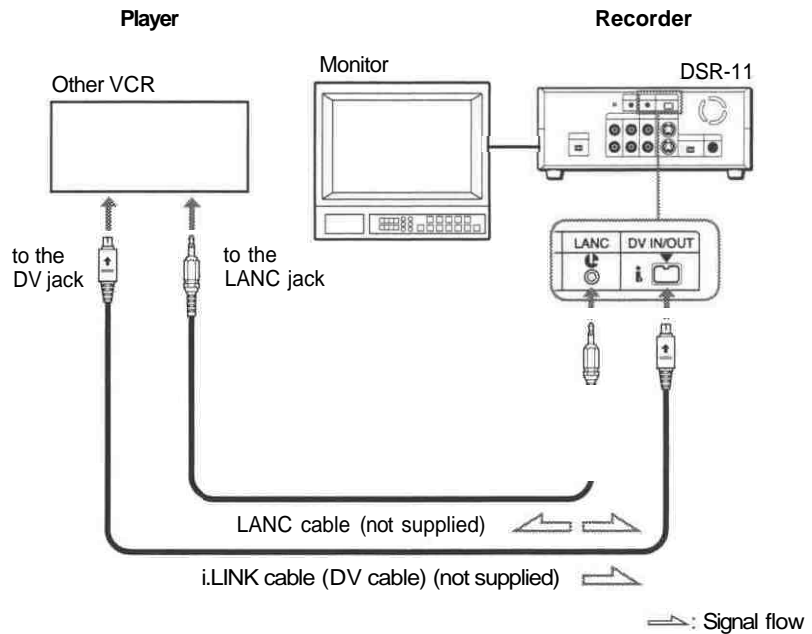

### Notes

- With the DV connection, the sound is recorded in the same audio recording mode as that of the source tape. To record in a different audio recording mode from the source tape, use the analog connection instead.
- With the DV connection, data codes (recording date/time, camera data) recorded on the source tape are transmitted from the other VCR (player). As a result, when you play back a recorded tape on this unit and press the DATA CODE button on the Remote Commander, the same data codes recorded on the source tape are displayed on the monitor screen. However, the contents of the cassette memory are not transmitted.
- If no picture appears via the DV jack, disconnect, then reconnect the i.LINK cable (DV cable).
- As for the LANC connection, see "Notes for the LANC connection" on the next page.

# Recording

## To video equipment without a DV jack

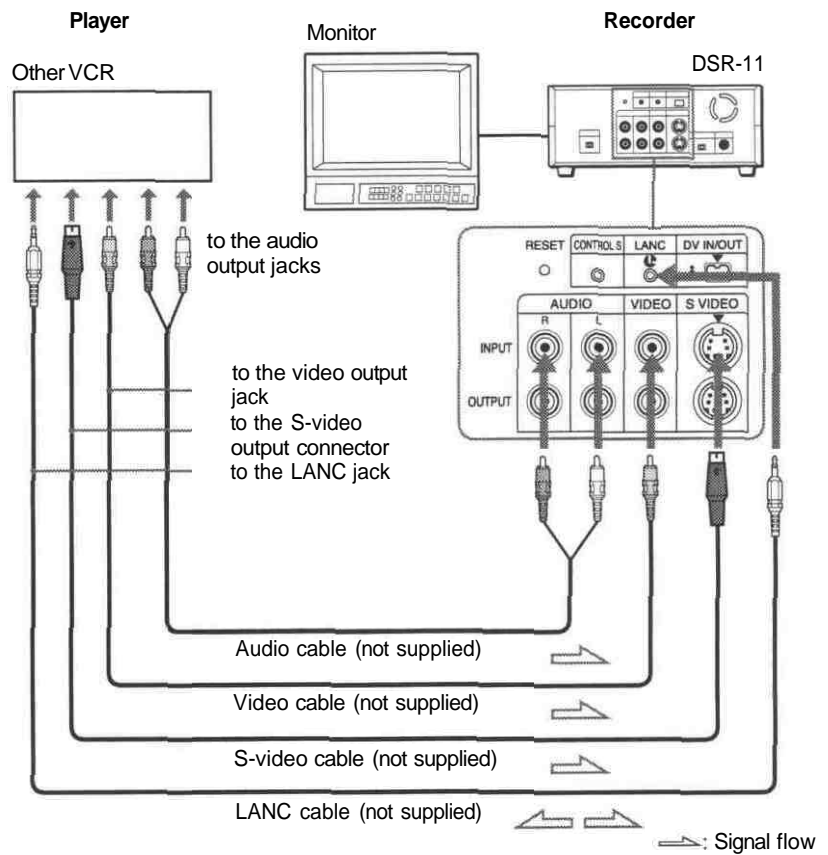

Connect either an S-video cable or a video cable as the cable for video signals.

### Notes

- When recording analog input signals, this unit can digitally output the signals from the DV IN/OUT connector for backup. Set DV EE OUT on the VTR SET menu to ON.  
*For details on the VTR SET menu, see "VTR SET menu" on page 43).*
- When you connect the output jacks of this unit to the input jacks of the player, select the input correctly with the INPUT SELECT selector on this unit to prevent a humming noise or distortion of the picture.
- Distorted signals (e.g., when played back at a speed other than normal) will not be recorded properly.

### Notes for the LANC connection

- The LANC connection transmits signals such as control signals, time code, time counter data, and status data.
- 'Jacks labeled CONTROL L have the same function as LANC jacks. Jacks labeled REMOTE may also have the same function.

## Settings for Recording

### Preparation on the recorder (this unit)

#### Notes

- Before recording, set the date and time on the unit so that the recording time can be written into the search signal. You can set the date and time by setting CLOCK SET on the OTHERS menu.

*For details on the OTHERS menu, see "OTHERS menu" on page 49.*

- Editing is not possible with a tape that is copyright protected.

**1** Power on the video monitor, then set the monitor's input switch according to the signals input from this unit.

**2** Set up the player to play back a tape.

*For details, refer to the instruction manual of the player.*

When the player is connected to the INPUT jacks on this unit, set the NTSC/PAL select switch on this unit to the appropriate position according to the input signals.

For NTSC formatted signals, set the switch to NTSC and for PAL formatted signals, set it to PAL.

*For details on the NTSC/PAL select switch setting, see "Rear Panel" on page 12.*

#### Notes

- Do not change the NTSC/PAL select switch setting during recording.
- If the color system of the input signals is different from that of the switch setting, both picture and sound will be muted.
- You do not need to set the NTSC/PAL select switch when inputting the signals to the DV IN/OUT connector. The unit detects the color system of the input signal automatically. However when the NTSC/PAL select switch is set to PAL, the time code generated by the unit while recording in DVCAM format turns to the non-drop frame mode. Even if an NTSC formatted signal is input from the DV IN/OUT connector, the time code generated by the unit is non-drop frame mode regardless of the TC FORMAT setting on the OTHERS menu. If you intend to set the unit to generate the time code in the drop frame mode, set the switch to NTSC.

**4** Power on this unit by pressing the ON/STANDBY switch on this unit.

(Continued)

- 5** Select an input signal by switching the INPUT SELECT selector on this unit.

**DV:** to record input signals from the DV IN/OUT connector

**S VIDEO:** to record input signals from the S VIDEO connector on the INPUT jacks

**VIDEO:** to record input signals from the VIDEO jack on the INPUT jacks

**Note**

Do not change the selector setting during recording. Otherwise, noise is output to the picture and sound and that portion will not be recorded properly.

- 6** When the player is connected to the INPUT jacks on this unit, select the audio mode.

Select the desired mode by setting AUDIO MODE on the AUDIO SET menu.

Audio mode	Set the menu to
4-channel mode	FS32K
2-channel mode	FS48K

*For details on the AUDIO SET menu, see "AUDIO SET menu" on page 44*

**Notes**

- In the DVCAM format, there are two audio modes, with either two channels at 48 kHz or four channels at 32 kHz. It is not possible to select other modes (for example with two channels at 32 kHz).
- When recording in 4-channel mode on this unit, audio signals are recorded only in channels 1/2. When you are going to dub sounds onto the tape, set AUDIO MODE to FS32K. (To dub a sound onto a tape (audio dubbing), you need another VCR that has audio dubbing capabilities. This unit does not have this function.)
- During recording, you cannot change the audio mode selection.

---

## Recording Procedure

This section describes the procedures used to record signals sent from another VCR to this unit. For details on the procedures required when using a computer as a player, refer to the instruction manual of your computer or the user's manuals of the software installed in it.

- 1** After checking that the REC/SAVE switch is set to REC, checking the tape for slack and confirming that the **[20]** indicator is off, hold the cassette so that the tape window is facing upward, then insert it into this unit.

*For details on the REC/SAVE switch and checking the tape for slack, see "Notes on Video Cassettes" on page 75 .*

The cassette is automatically loaded into the unit and the tape will stop.

- 2** Press the playback button on the player.

The player starts playback.

- 3** Press the PLAY button while holding down the REC button.

The unit starts recording and the index is marked.

### **To stop recording**

Press the STOP button on the unit.

### **To pause recording**

Press the PAUSE button on the unit.

### **To display useful data for recording on the monitor screen**

Press the DISPLAY button on the Remote Commander.

*For details on displayed data, see "Displaying various data " on page 26 ..*

# Installing the Unit Vertically

## To install the unit

Put the unit into the supplied rack as illustrated below. You can install it either standing on its left side or on its right side.

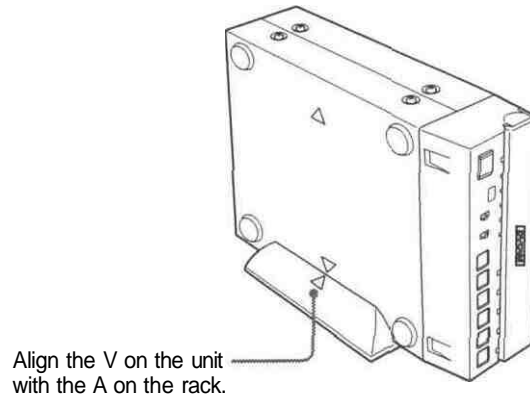

### Notes

- Be sure to use the supplied rack. Without the rack, the unit may topple over and may be damaged or may cause injury.
- Install the unit on a flat place.
- When inserting a cassette, especially a mini cassette, hold it until it is loaded into the unit. Otherwise the cassette may fall out and the tape may be damaged.

*For details on inserting a cassette, see "Notes on Video Cassettes" on page 15*



# Adjusting and Setting Through Menus

## Operating the Menus

The unit allows you to set various parameters in the menus. Before you start using the unit, set the internal clock in CLOCK SET on the OTHERS menu. Except for clock setting, you can use all other factory-set default parameters but change them as needed.

**Note**

If the internal backup battery is exhausted, the menu settings will be initialized. The internal backup battery is fully charged if you connect the power to the unit for about 10 hours. The menu settings will be kept for about one month.

### Displaying the menu

Press the MENU button on the Remote Commander.  
The menu is superimposed on the analog video output.

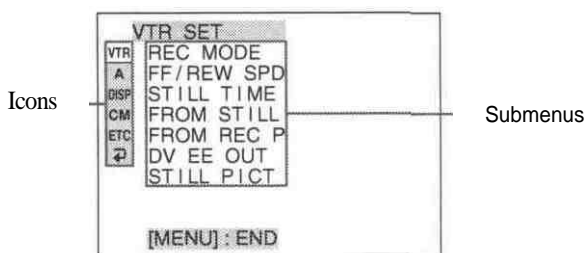

### Changing the menu settings

- 1** Pressing the **↑/↓** buttons on the Remote Commander, select the menu icon you want to change, then press the SET button on the Remote Commander.
- 2** Pressing the **↑/↓** buttons, select the submenu you want to change, then press the SET button.
- 3** Pressing the **↑/↓** buttons, change the setting.
- 4** Press the SET button to return to the submenu.
- 5** Repeat steps 2 to 4, as needed.

#### To return to step 1

Pressing the **↑/↓** buttons, select **⇨RETURN**, then press the SET button.

#### To exit from the menu

Press the MENU button again.

# Operating the Menus

## Menu Organization

The menu of this unit consists of the following menus and submenus.

Menu	Submenu (page)
VTR SET	— REC MODE (page 43)
	— FF/REW SPD (page 43)
	— STILL TIME (page 43 )
	— FROM STILL (page 44 )
	— FROM REC P (page 44 )
	— DV EE OUT (page 44 )
1— STILL PICT (page 44 )	
AUDIO SET	— AUDIO MODE (page 44 )
	— JOG AUDIO (page 45 )
	1— AUDIO MIX (page 45)
DISPLAY SET-T	— [^REMAIN (page 45 )
	— DATA CODE (page 45 )
	— COLOR BAR (page 45 <sup>a</sup> )
	— DATE DISP (page 45 )
	— TIME DISP (page 45 )
CM SET	— CM SEARCH (page 46 )
	— TITLE DISP (page 46 )
	— LABEL DISP (page 46 )
	— TAPE LABEL (page 46 )
	— ITEM ERASE (page 47 )
	— ERASE ALL (page 48 )
OTHERS	— DV IN TC (page 49 )
	— TC FORMAT (page 49 )
	— CLOCK SET (page 49)
	1— HRS METER (page 49 )

a) COLOUR BAR for PAL model

b) available only when you use an NTSC formatted signal

# Menu Contents

Initial settings are indicated with rectangles.

## VTR SET menu

Icon/Menu	Submenu (page)	Setting
 VTR SET	REC MODE	<p>Switches the recording mode between DVCAM and DV (SP mode only). When you play back a tape, the DVCAM/DV setting will be automatically switched; you do not need to use this item.</p> <p><b>DVCAM</b> Records in DVCAM format.  <b>DV SP:</b> Records in DV format (SP mode).</p> <p><b>Notes</b></p> <ul style="list-style-type: none"> <li>• This unit is not compatible with playing or recording in LP mode of the consumer DV format.</li> <li>• You cannot change the setting while recording.</li> <li>• It is recommended that you record in the DVCAM format. There are some limitations with respect to DV recording depending on machine specifications and the consumer DV format as follows: <ul style="list-style-type: none"> <li>- The head system is optimized for DVCAM recording. A DV recording overwrites the last track just before the beginning of the recording. As a result, at the border of these two recorded portions, picture and sound may be distorted.</li> <li>- The sound will be recorded unsynchronized. (unlock mode)</li> <li>- The time code is fixed to the drop frame mode. (only for NTSC)</li> <li>- The DV IN TC setting on the OTHERS menu turns invalid. The unit records internal time code.</li> </ul> </li> <li>• If you dub a consumer DV tape from the DV IN/OUT connector on this unit, keep the following in mind: <ul style="list-style-type: none"> <li>- Set the REC MODE to DV SP. If the REC MODE has been set to DVCAM, a tape with an invalid format (recording speed: DVCAM, sound: unsynchronized, unlock mode) will be made. (The unit cannot convert unlock mode sound to lock mode sound.)</li> <li>- If you edit a tape with an invalid format in the DSR-70/70P, DSR-80/80P, DSR-85/85P, DSR-2000/2000P, etc., there may be some restrictions.</li> </ul> </li> </ul> <p><i>For details on DVCAM/DV format compatibility, see "Compatibility of DVCAM and DV Format" on page 55.</i></p>
	FF/REW SPD	<p>Selects the tape transport mode in fast-forward and rewind.</p> <p><b>FF/REW</b> Fast-forwards or rewinds the tape at maximum speed without displaying the picture.</p> <p><b>SHUTTLEMAX:</b> Fast-forwards or rewinds the tape at maximum speed (about 14 times normal speed for NTSC; about 17 times normal speed for PAL) while displaying the picture.</p>
	STILL TIME	<p>Selects the time to switch to the tape protection mode from the still mode.</p> <p><b>30 SEC:</b> 30 seconds  <b>1 MIN:</b> 1 minute  <b>2 MIN:</b> 2 minutes  <b>3 MIN:</b> 3 minutes  <b>5 MIN:</b> 5 minutes</p> <p><b>Notes</b></p> <ul style="list-style-type: none"> <li>• If the unit is left in playback pause mode for a long time, the tape or the video heads may be damaged or the video heads may become clogged. Select the shortest time possible—particularly when using a Mini-DV cassette that is longer than 60 minutes, select 30 SEC or 1 MIN.</li> <li>• When the setting is changed, the first tape protection mode change uses the time setting from before the settings were changed. From the second tape protection mode change, the new time setting is used.</li> </ul>

(Continued)

# Operating the Menus

Icon/Menu	Submenu (page)	Setting
VTR VTR SET	FROM STILL	Selects the tape protection mode which to change the mode from the still mode. <input type="checkbox"/> <b>STEP FWD</b> : Forwards one frame. <b>STOP</b> : Stops the tape.
	FROM REC P	Selects the tape protection mode that the system changes to after the recording has been paused for more than five minutes. <input type="checkbox"/> <b>STOP</b> : Stops the tape. <b>REC PAUSE</b> : Maintains the recording pause mode.
DV EE OUT (page 36 )		Selects the output from the DV IN/OUT connector in the EE mode. <input type="checkbox"/> <b>OFF</b> : Does not output DV signals converted from analog input signals. <input type="checkbox"/> <b>ON</b> : Outputs DV signals from the DV IN/OUT connector that were converted from selected analog input signals.
		<p><b>Notes</b></p> <ul style="list-style-type: none"> <li>• During playback, the unit outputs DV signals from the DV IN/OUT connector regardless of this setting.</li> <li>• When you connect a computer to the DV IN/OUT connector, depending on your computer software, the selected analog input signals may be output to the computer even if this item is set to OFF.</li> </ul>
	STILL PICT	Selects the image displayed in the still mode. <input type="checkbox"/> : Displays an optimized image according to the movement in the image. <input type="checkbox"/> <b>FRAME</b> : Displays a frame image. <input type="checkbox"/> <b>FIELD</b> : Displays a field image.
		<p><b>Note</b></p> <p>If you select FIELD, the image of field 2 is displayed.</p>

## AUDIO SET menu

Icon/Menu	Submenu (page)	Setting
A AUDIO SET	AUDIO MODE (page 38 )	Selects the audio mode. <input type="checkbox"/> Switches the audio mode to the four channel mode (12-bit mode). <input type="checkbox"/> <b>FS48K</b> : Switches the audio mode to the two channel stereo mode (16-bit mode). (This setting records the sound in all audio ranges, providing a high-quality sound recording.)
		<p><b>Notes</b></p> <ul style="list-style-type: none"> <li>• This item is disabled when inputting signals from the DV IN/OUT connector.</li> <li>• You cannot display the selection screen while in the recording mode.</li> <li>• Noise may occur at the moment you switch the audio mode.</li> <li>• When you are going to dub sounds onto the tape, set this item to FS32K. (To dub a sound onto a tape, you need another VCR which has audio dubbing capabilities. This unit does not have this function.)</li> </ul>

Icon/Menu	Submenu (page)	Setting
A AUDIO SET	JOG AUDIO	Turns sound output on/off when the tape is played at a speed other than normal. <b>OFF</b> : Does not output the sound when playing a tape at a speed other than normal. <b>ON</b> : Outputs the sound when playing a tape at a speed other than normal. <b>Note</b> Even if you have set this item to ON, the sound may not be output or may be interrupted depending on the recording format or tape conditions.
	AUDIO MIX (page 23 (GB))	Adjust the balance of the analog audio output level between channels 1/2 and channels 3/4 during playback. Press the $\uparrow/\downarrow$ buttons to move the bar, then press the SET button. 



## DISPLAY SET menu

Icon/Menu	Submenu (page)	Setting
DISP DISPLAY SET	REMAIN (page 27 (GB))	Selects whether or not to display the tape remaining time on the analog video output. <b>ON</b> : Displays the tape remaining time. <b>OFF</b> : Does not display the tape remaining time.
	DATA CODE (page 25 (GB))	Selects whether or not to display the data codes on the analog video output. <b>OFF</b> : Does not display the data codes. <b>DATE</b> : Displays the date and time when recorded. <b>CAMERA</b> : Displays the camera data.
	COLOR BAR (for NTSC model) / COLOUR BAR (for PAL model)	Selects whether or not to display the color bars. <b>OFF</b> : Does not display the color bars. <b>ON</b> : Displays the color bars. <b>Notes</b> <ul style="list-style-type: none"> <li>You cannot display the color bars while the unit is playing the tape or when the INPUT SELECT selector is set to DV.</li> <li>The color bars are displayed only on the analog video output.</li> <li>If you record when the color bars are displayed, the color bars will also be recorded on the tape.</li> <li>Do not use the color bars output from the OUTPUT jacks as a reference signal.</li> <li>The reference sound signals are not output even if this item is set to ON.</li> <li>This item will be automatically set to OFF if you set the INPUT SELECT selector to DV or you operate the tape transport control that display the pictures recorded on the tape.</li> </ul>
	DATE DISP	Selects the date display in the search screen, the data code display and so on. <b>Y/M/D</b> : Displays YY/MM/DD (year/month/day). <b>M/D/Y</b> : Displays MM/DD/YY (month/day/year). <b>D/M/Y</b> : Displays DD/MM/YY (day/month/year). <b>Note</b> The default is M/D/Y for the NTSC model; D/M/Y for the PAL model.
	TIME DISP	Selects the time display in the search screen, the data code display and so on. <b>24H</b> : Displays 24-hour time. <b>12H</b> : Displays 12-hour time.

# Operating the Menus

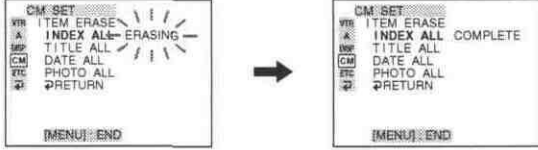

## CM SET menu

Icon/Menu	Submenu (page)	Setting
CM CM SET	CM SEARCH (page 29 (GB))	<p>Selects the mode which searches recordings.</p> <p><b>ON</b>: Searches recordings using the cassette memory. (If the tape does not have cassette memory, the beginning of recording is searched for using the search signals on the tape.)</p> <p><b>OFF</b>: Always searches recordings using the search signals on the tape.</p>
	TITLE DISP	<p>Selects whether or not to display the title.</p> <p><b>ON</b>: Displays the superimposed title for about five seconds when the unit plays back the point where the title is recorded.</p> <p><b>OFF</b>: Does not display the title.</p> <p><b>Notes</b></p> <ul style="list-style-type: none"> <li>The title that has been made with the camera or an external device is displayed. You cannot make a title with this unit.</li> <li>The unit cannot display a font that the unit does not have.</li> <li>The title is displayed only on the analog video output.</li> </ul>
	LABEL DISP	<p>Selects whether or not to display the tape label.</p> <p><b>ON</b>: Displays the tape label for about five seconds when a cassette that has a tape label is inserted.</p> <p><b>OFF</b>: Does not display the tape label.</p> <p><b>Notes</b></p> <ul style="list-style-type: none"> <li>The tape label is displayed only on the analog video output.</li> <li>If the tape label has been made with an other VCR or camcorder, this unit cannot display a tape label that includes a font that the unit does not have.</li> </ul>
	TAPE LABEL	<p>Makes a tape label. (You can enter up to 10 characters on a tape label.)</p> <p>If you select this item, one of the following symbols appears. If no cassette is loaded, nothing is displayed.</p> <p><b>CM</b>: Tape with cassette memory</p> <p><b>CM</b>: Tape without cassette memory</p> <p>You can make a tape label as follows:</p> <ol style="list-style-type: none"> <li>On the TAPE LABEL screen, select the line that has the alphabet character you want by pressing the <b>↑/↓</b> and SET buttons. (The cursor moves to the first character of the line.)</li> </ol> <div style="display: flex; align-items: center; justify-content: center;"> <div style="border: 1px solid black; padding: 5px; margin-right: 10px;"> <p>TAPE LABEL <b>CM</b></p> <p>AB CDE 12345</p> <p>FGHIJ 67890</p> <p>KLMNO . / -</p> <p>PQRST [ - ]</p> <p>UVWXY [ SET ]</p> <p>Z&amp; ?!</p> <p>[MENU]:END</p> </div> <div style="font-size: 2em; margin-right: 10px;">→</div> <div style="border: 1px solid black; padding: 5px;"> <p>TAPE LABEL <b>CM</b></p> <p>AB CDE 12345</p> <p>FGHIJ 67890</p> <p>KLMNO . / -</p> <p>PQRST [ - ]</p> <p>UVWXY [ SET ]</p> <p>Z&amp; ?!</p> <p>[MENU]:END</p> </div> </div> <ol style="list-style-type: none"> <li>Select a character by pressing the <b>↑/↓</b> and SET buttons. (The selected character is entered. To erase a character, select [ ← ]; the last character is erased.)</li> </ol> <div style="display: flex; align-items: center; justify-content: center;"> <div style="border: 1px solid black; padding: 5px; margin-right: 10px;"> <p>TAPE LABEL <b>CM</b></p> <p>AB CDE 12345</p> <p>FGHIJ 67890</p> <p>KLMNO . / -</p> <p>PQRST [ - ]</p> <p>UVWXY [ SET ]</p> <p>Z&amp; ?!</p> <p>[MENU]:END</p> </div> <div style="font-size: 2em; margin-right: 10px;">→</div> <div style="border: 1px solid black; padding: 5px;"> <p>TAPE LABEL <b>CM</b></p> <p>S</p> <p>AB CDE 12345</p> <p>FGHIJ 67890</p> <p>KLMNO . / -</p> <p>PQRST [ - ]</p> <p>UVWXY [ SET ]</p> <p>Z&amp; ?!</p> <p>[MENU]:END</p> </div> </div>

Icon/Menu	Submenu (page)	Setting
 CM SET	TAPE LABEL	<p><b>3</b> Repeat steps 1 and 2. After entering all characters for the tape label, select [SET].</p> <p><b>Note</b></p> <p>The unit cannot display the TAPE LABEL screen in the following cases:</p> <ul style="list-style-type: none"> <li>• The unit does not have a tape inserted or the tape is being unloaded.</li> <li>• The tape does not have cassette memory.</li> <li>• The cassette memory is full of data other than the tape label data.</li> <li>• The tape is write-protected.</li> <li>• The tape is being recorded.</li> <li>• The cassette memory is being used.</li> </ul>
	ITEM ERASE	<p>Erases a cassette memory item.</p> <p>If you select this item, one of the following symbols appears. If no cassette is loaded, nothing is displayed.</p> <p><b>CM</b>: Tape with cassette memory  <b>CM</b>: Tape without cassette memory</p> <p>The available items are as follows:</p> <p><b>INDEX ALL</b>: Erases the index data.  <b>TITLE ALL</b>: Erases the title data.  <b>DATE ALL</b>: Erases the date data.  <b>PHOTO ALL</b>: Erases the photo data.</p> <p>You can erase an item as follows:</p> <ol style="list-style-type: none"> <li>1 Select an item to erase by pressing the <math>\uparrow/\downarrow</math> and SET buttons.</li> <li>2 To erase the item, select OK, otherwise select RETURN. (If you select OK, the unit will check again to see if you really want to erase the item.)</li> </ol> <div style="text-align: center;">  </div> <ol style="list-style-type: none"> <li>3 To erase the item, select EXECUTE, otherwise select RETURN. (If you select EXECUTE, the ERASING message will flash, and the unit will start erasing the item in the cassette memory. While the ERASING message is flashing, you cannot use the <math>\uparrow/\downarrow</math> or SET buttons. After the item has been erased, the COMPLETE message appears. Press the <math>\uparrow/\downarrow</math> button to erase the COMPLETE message.)</li> </ol> <div style="text-align: center;">  </div> <p><b>Notes</b></p> <ul style="list-style-type: none"> <li>• You cannot make a title, mark the date for date search, or record in the photo mode with this unit.</li> <li>• You cannot erase an item in the cassette memory in the following cases:             <ul style="list-style-type: none"> <li>– The unit does not have a tape inserted or the tape is being unloaded.</li> <li>– The tape does not have cassette memory.</li> <li>– The tape is write-protected.</li> <li>– The tape is being recorded.</li> <li>– The cassette memory is being used.</li> </ul> </li> </ul>

(Continued)

# Operating the Menus

Icon/Menu	Submenu (page)	Setting
 CM SET	ERASE ALL	<p>Erases all items in the cassette memory.            If you select this item, one of the following symbols appears. If no cassette is loaded, nothing is displayed.</p> <p>: Tape with cassette memory  : Tape without cassette memory</p> <p>Erase all items in the cassette memory as follows:</p> <p><b>1</b> To erase all items, select OK, otherwise select RETURN. (If you select OK, the unit will check again to see if you really want to erase all items.)</p> <div style="display: flex; align-items: center; justify-content: space-around;"> <div style="border: 1px solid black; padding: 5px; width: 150px;"> <pre> CM SET VR CM SEARCH A TITLE DISP DISP LABEL DISP CM TAPE LABEL ITEM ERASE ERASE ALL RETURN RETURN OK [MENU] END           </pre> </div> <div style="font-size: 2em;">→</div> <div style="border: 1px solid black; padding: 5px; width: 150px;"> <pre> CM SET VR CM SEARCH A TITLE DISP DISP LABEL DISP CM TAPE LABEL ITEM ERASE ERASE ALL RETURN RETURN OK [MENU] END           </pre> </div> <div style="font-size: 2em;">→</div> <div style="border: 1px solid black; padding: 5px; width: 150px;"> <pre> CM SET VR CM SEARCH A TITLE DISP DISP LABEL DISP CM TAPE LABEL ITEM ERASE ERASE ALL RETURN RETURN EXECUTE [MENU] END           </pre> </div> </div> <p><b>2</b> To erase all items, select EXECUTE, otherwise select RETURN. (If you select EXECUTE, the ERASING message will flash, and the unit starts erasing all items in the cassette memory. While the ERASING message is flashing, you cannot use the ↑/↓ or SET buttons. After all items have been erased, the COMPLETE message appears. Press the ↑/↓ button to erase the COMPLETE message.)</p> <div style="display: flex; align-items: center; justify-content: space-around;"> <div style="border: 1px solid black; padding: 5px; width: 150px;"> <pre> CM SET VR CM SEARCH A TITLE DISP DISP LABEL DISP CM TAPE LABEL ITEM ERASE ERASE ALL ERASING RETURN [MENU] END           </pre> </div> <div style="font-size: 2em;">→</div> <div style="border: 1px solid black; padding: 5px; width: 150px;"> <pre> CM SET VR CM SEARCH A TITLE DISP DISP LABEL DISP CM TAPE LABEL ITEM ERASE ERASE ALL COMPLETE RETURN [MENU] END           </pre> </div> </div> <p><b>Note</b></p> <p>You cannot erase all items in the cassette memory in the following cases:</p> <ul style="list-style-type: none"> <li>• The unit does not have a tape inserted or the tape is being unloaded.</li> <li>• The tape does not have cassette memory.</li> <li>• The tape is write-protected.</li> <li>• The tape is being recorded.</li> <li>• The cassette memory is being used.</li> </ul>



## OTHERS menu

Icon/Menu	Submenu (page)	Setting
ETC OTHERS	DV IN TC	<p>Selects whether to record internal time code or external time code while the unit records the signals input from the DV IN/OUT connector in DVCAM format.</p> <p><b>INTERNAL</b> : Records the time code generated by the internal time code generator. (If no time code is recorded on the tape, the unit records time code from 00:00:00:00. If there is time code already recorded on the tape, the unit records continuous time code from this point.)</p> <p><b>EXTERNAL</b>: Records the time code with video and audio signals input from the DV IN/OUT connector.</p> <p><b>Notes</b></p> <ul style="list-style-type: none"> <li>• When you set the REC MODE on the VTR SET menu to DV SP, this item cannot be used. Even if it is once set to EXTERNAL, the setting turns invalid and the unit records the internal time code when you set REC MODE on the VTR SET menu to DV SP.</li> <li>• When this item is set to EXTERNAL, the INPUT SELECT selector on the front panel is set to DV, and no signal is input from the DV IN/OUT connector, if you start recording, bars (— :—:—:—) are recorded as time code. At the point that inputting of a signal begins, the time code of that signal will be recorded.</li> <li>• If you set this item to EXTERNAL and the external time code input is discontinuous or does not advance correctly, recording or displaying the time code on this unit may not be done correctly. If there is a discontinuous time code on your recorded tape, you may not be able to edit or search correctly, depending on the device used to edit.</li> </ul>
	TC FORMAT	<p>Selects the frame mode.</p> <p><b>AUTO</b> : Automatically sets the frame mode in accordance with the inserted cassette. (If nothing is recorded on the tape, the mode is set to the non-drop frame mode. If the unit cannot read the frame mode correctly in the tape, the unit will use the frame mode that was set in the last position it was able to read correctly on the tape. If you turn the power on/off or remove the tape, the mode of the last position it was able to read correctly is cleared and the mode is set to the non-drop frame mode.)</p> <p><b>DF</b>: Selects the drop frame mode.</p> <p><b>NDF</b>: Selects the non-drop frame mode.</p> <p><b>Notes</b></p> <ul style="list-style-type: none"> <li>• When the NTSC/PAL select switch is set to PAL, the unit works as a PAL model. Therefore while recording in the DVCAM format, the time code generated by the unit turns to the non-drop frame mode. Even if an NTSC formatted signal is input from the DV IN/OUT connector, the time code generated by the unit is non-drop frame mode as long as the switch is set to PAL, regardless of this item setting. If you intend to set the unit to generate the time code in the drop frame mode, set the NTSC/PAL select switch to NTSC.</li> <li>• Regardless of this setting, the frame mode is set to drop frame when you record in DV format (Only for NTSC).</li> </ul>
	CLOCK SET (page 37 (GB))	<p>Sets the internal clock of the unit.</p> <p>Pressing the <math>\uparrow/\downarrow</math> and SET buttons, sets the time (year, month, day, hour and minute). (When you set the minute, the second count will start from 00.)</p> <p><b>Notes</b></p> <ul style="list-style-type: none"> <li>• This item cannot be set during recording.</li> <li>• Regardless of the DATE DISP setting on the DISPLAY SET menu, the date for CLOCK SET is displayed in the Y/M/D order.</li> <li>• The internal backup battery will be fully charged in about 10 hours when power is provided to the unit. A fully charged internal backup battery can run the internal clock for about one month without the power provided through the AC adaptor.</li> </ul>
	HRS METER (page 53 (GB))	<p>Displays the accumulated time counts (by the digital hours meter) in units of 10 hours or 10 counts.</p> <p><b>OPERATION</b>: Power on duration</p> <p><b>DRUM RUN</b>: Drum rotation duration</p> <p><b>TAPE RUN</b>: Tape run duration</p> <p><b>THREADING</b>: Tape unthreading count</p>

# Maintenance

## Troubleshooting







Please check the following before contacting your Sony dealer.

Symptom	Cause/Remedy
The power cannot be turned on.	The AC adaptor is disconnected. --- Connect the AC adaptor.
The unit will not operate even if the power has been turned on.	<ul style="list-style-type: none"> <li>Moisture condensation has occurred. --- Turn off the power and disconnect the AC adaptor. Connect the AC adaptor after about one minute and turn on the power. Then, if there is a cassette in the unit, remove the cassette and keep the cassette lid open, power on the unit and leave it on for more than one hour.</li> <li>The cassette is not inserted straight. --- Insert it straight.</li> </ul>
The cassette cannot be inserted.	<ul style="list-style-type: none"> <li>There is moisture condensation on the head drum. --- Keep the cassette lid open and turn the power on. Then, wait more than one hour.</li> <li>The cassette is not inserted straight. --- Insert it straight.</li> <li>Another cassette has been loaded already.--- Remove the cassette and insert the one you want to load.</li> </ul>
It takes time to eject the cassette.	This is not a malfunction.--- This unit ejects the cassette slowly to protect the tape.
No picture.	The video heads are dirty. --- Clean the video heads using the supplied cleaning cassette.
Noise appears on the screen.	<ul style="list-style-type: none"> <li>A damaged cassette is inserted. --- Insert another cassette.</li> <li>The video heads are dirty. --- Clean the video heads using the supplied cleaning cassette.</li> </ul>
No picture via the DV jack.	<ul style="list-style-type: none"> <li>Reconnect the i.LINK cable (DV cable) (not supplied).</li> <li>The INPUT SELECT selector is set to other than DV. --- Set it to DV.</li> </ul>
The audio is noisy.	A damaged cassette is inserted. --- Insert another cassette.
Pause is released automatically.	Pause mode is automatically released to protect the tape.
The picture and sound are muted in the EE or recording mode.	The NTSC/PAL select switch setting is not appropriate. --- Set it to a suitable position for the color system of the input signals.
The Remote Commander or remote control unit does not work.	The REMOTE CONTROL switch setting is not appropriate. --- Set it to a suitable position for the device you use.
Though DV IN TC on the OTHERS menu was set to EXTERNAL, the time code of the signals input from the DV IN/OUT connector cannot be recorded.	The REC MODE on the VTR SET menu is set to DV SP. Set the REC MODE to DVCAM.
When the unit is recording an NTSC formatted signal input from the DV IN/OUT connector in DVCAM format, even if the TC FORMAT on the OTHERS menu is set to DF, the time code is recorded in non-drop frame mode.	The NTSC/PAL select switch is set to PAL. --- Set it to NTSC.

# Alarm Messages

If an error occurs, a caution appears on the analog video outputs when you set the unit to output signals with data items. Check them with the following list.

For details on data items, see "Displaying various data" on page 26

Monitor	Indicator lamp (flash) <sup>a)</sup>	Description/Recovery
	CAUTION	
	Rapid flashing	Moisture condensation (without a cassette) —»• Keep the cassette lid open and turn the power on, then wait more than one hour.
	Rapid flashing	Moisture condensation (with a cassette) —»• Remove the cassette and keep the cassette lid open and turn the power on, then wait more than one hour.
 NO TAPE	Slow flashing	You tried to record without a cassette inserted. —»• Insert a cassette.
	Slow flashing	The tape is reaching the end during recording. —»• Provide a new cassette.
 TAPE END	Slow flashing	The tape reached the end and still tried to record. —»• Rewind the tape or replace the tape with a new one.
	Slow flashing	The cassette is write-protected (The REC/SAVE switch is set to SAVE) and you tried to record. —»• Set the REC/SAVE switch to REC or use another cassette (See page 16 .
CLOCK SET		You did not set the clock when you turned on the unit. —»• Set the clock with the menu (See page 49)
COPY INHIBIT	Slow flashing	You tried to record a copyright-protected source. —»• You cannot record a copyright-protected source (See page 19.
 CLEANING CASSETTE	Rapid flashing	The video heads are clogged. —»• Clean the video heads with the supplied cleaning cassette. (The unit detects if the video heads are clean only before recording. If the video heads get clogged during recording, the unit cannot detect it.)
	Rapid flashing	The unit is running the self-diagnostics (See page 54 . This caution display ceases when you turn on/off the power of the unit.

a: The indicator flashes 3.2 times per second in the rapid flashing mode and flashes 0.8 time per second in the slow flashing mode.

## Notes on the video cassette recorder

### Do not install the unit in a place subject to direct sunlight or heat sources

If you do, its cabinet, mechanical parts, etc., may be damaged.

### Do not install the unit in an extremely hot place

If the unit is left in a car parked with its windows closed (especially in summer), its cabinet may be damaged or it may not work correctly.

### If the unit is brought directly from a cold to a warm location

Moisture may condense inside the unit and cause damage to the video head and tape. If you use the unit in a place subject to direct cold currents from an air conditioner, moisture may also condense inside the unit.

### Do not place a heavy object on the unit

The cabinet may be damaged, or the unit may not work correctly.

### Do not handle the unit roughly

Avoid rough handling or mechanical shock.

### To avoid damaging the cabinet finish

Plastic is often used for the surface finishing of the unit. Do not spray a volatile solvent such as an insecticide toward the cabinet or place rubber or vinyl products on the cabinet for a long time. If you do, the finish of the cabinet may be damaged or the coating may come off.

### Do not clean the cabinet with thinner or benzine

The cabinet may be damaged or its coating may come off. When you use a chemical-impregnated cloth, use it according to its directions.

### Clean the cabinet with soft dry cloth

When the cabinet is very dirty, clean it with a soft dry cloth lightly moistened with a mild detergent solution and finish it with a dry cloth.

### Do not put magnetic objects close to the unit

Magnetic fields may damage the recording.

### To prevent electromagnetic interference caused by radio communication equipment such as cellular phones, transceivers, etc.

The use of the radio communication equipment such as cellular phones or transceivers near the unit may cause a malfunction and can affect the audio/video signals. The cellular phones or transceivers near the unit should be switched off.

### Do not use the unit in an area exposed to radiation

A malfunction may occur.

### Checking the video heads every 1000 hours

A VCR is a high-precision piece of equipment that records and plays back the picture on a magnetic tape. In particular, the video heads and other mechanical parts become dirty or worn. To maintain a clean picture, we recommend maintenance every 1000 hours, though the conditions of use may differ depending on temperature, humidity, dust, etc.

## Cleaning of the video heads

If the video heads are contaminated, the pictures cannot be recorded properly or the playback pictures become noisy. If the following phenomena occur, use the cleaning cassette (supplied) to clean the heads.

- Square-shaped noise appears on the playback picture.
- A part of the playback picture does not move.
- The playback picture does not appear on the screen.

### Symptoms caused by contaminated video heads

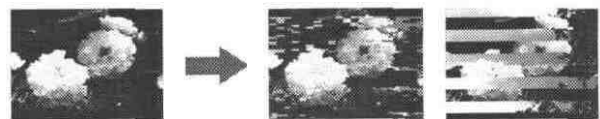

Normal picture

If these images appear on the screen, use the cleaning cassette.

### To use the cleaning cassette

Refer to your cleaning cassette's operating instructions

After prolonged use, the video heads may become worn out. If optimum picture quality is not restored even after you have cleaned the video heads with the cleaning cassette, the video heads may have worn out. In that case, you have to replace the video heads with new ones. Please consult your Sony dealer.

---

## Notes on the video cassettes

### If the cassette memory function does not work

Reinsert the cassette a few times. The terminal portion of the cassette may be dusty or dirty.

### Cleaning the terminal

If the terminal of the cassette gets dirty, or dust sticks to the terminal, the unit may not work correctly. Clean the terminal with a swab once every ten times you eject a cassette.

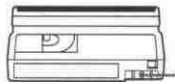

Terminal

### When affixing a label on the cassette

Be sure to affix a label only on the correct location so as not to cause malfunction of the unit.

### After using a cassette

After use, please be sure to rewind the tape completely (to prevent picture and sound distortion). Return it to its case and store it in an upright position.

## About moisture condensation

If the unit or tape is brought directly from a cold to a warm location, moisture may condense inside or outside the unit or tape. If you use the tape or video heads in this condition, the tape may adhere to the head drum, and the video heads or the tape may be damaged, or a malfunction may occur.

Moisture condensation is likely to occur under the following conditions:

- The unit or tape is brought from the cold outdoors to a warm indoor location.
- The unit or tape is brought from the air-conditioned indoors to the hot outdoors.
- The unit is used in a place subject to cold currents from an air conditioner.

When bringing the unit or tape from a cold place to a warm place or vice versa, put it in a plastic bag and seal the bag tightly. After bringing it into the new place, leave the bag on for more than one hour, and remove the bag when the air temperature inside it has reached the temperature surrounding it.

### If moisture condensation occurred

You cannot operate the unit except to press the EJECT button, and the cassette cannot be inserted. If this occurs, turn on the power to remove the cassette, then keep opening the cassette lid, and finally wait more than one hour for the moisture to evaporate.

## Digital hours meter

The digital hours meter keeps cumulative counts of the total operation time, the head drum rotation time, the tape running time and the number of unthreading operations. These counts can be displayed on the monitor screen. Use them as guidelines for scheduling maintenance.

In general, consult your Sony dealer about necessary periodic maintenance checks.

The digital hours meter has the following four display modes and you can check them in HRS METER of the OTHERS menu (See page 49).

#### •OPERATION mode

The cumulative total hours of operating time is displayed in 10-hour increments.

#### •DRUM ROTATION mode

The cumulative total hours of drum rotation with tape threaded is displayed in 10-hour increments.

#### •TAPE RUN mode

The cumulative total hours of tape running time is displayed in 10-hour increments.

#### •THREADING mode

The cumulative number of tape unthreading operations is displayed in 10-operation increments.

## Notes on Use

### Self-diagnostics function

The unit has a self-diagnostics display function. This function displays the current condition of the unit as a five-digit code (a combination of a letter and numbers) on the analog video output. If a five-digit code is displayed, check the following code chart. The last two digits (indicated by DD) will differ depending on the state of your unit.

Code	Symptom	Remedy
C:21:DD	Moisture condensation has occurred.	Remove the cassette and keep the cassette lid open and turn the power on. After waiting more than one hour, insert the cassette again.
C:22:DD	The video heads are dirty.	Clean the heads using the cleaning cassette (supplied).
C:31:DD	To prevent the unit from malfunctioning, the self-diagnostics function has taken over.	<ul style="list-style-type: none"><li>• Remove the cassette, or turn on/off the unit.</li><li>• Disconnect the AC adaptor. After reconnecting it, operate the unit.</li></ul>
C:32:DD	To prevent the unit from malfunctioning, the self-diagnostics function has taken over.	<ul style="list-style-type: none"><li>• Turn on/off the unit.</li><li>• Disconnect the AC adaptor. After reconnecting it, operate the unit.</li></ul>

If you are unable to resolve the problem, or a code other than those in the above chart appears, contact your Sony dealer or local authorized Sony service facility and inform them of the number.

# Appendix

## Compatibility of DVCAM and DV Format

The DVCAM format was developed as a more reliable and higher end format than the consumer DV format. Here we explain the DVCAM and DV formats: the differences, compatibility and limitations on editing.

### Differences between DVCAM and DV format

Item	DVCAM	DV
Track pitch	15 $\mu$ m	10 <i>µm</i>
Audio sampling frequency	12 bit: 32 kHz 16 bit: 48 kHz	12 bit: 32 kHz 16 bit: 32 kHz, 44.1 kHz, 48 kHz <sup>2)</sup>
Audio recording mode <sup>1)</sup>	Lock mode	Unlock mode
Time code system	NTSC; SMPTE time code (DF/NDF/including user bits) <sup>3)</sup> PAL; EBU time code (including user bits) <sup>3)</sup>	Drop frame mode (NTSC) without user bits

- 1) There are two modes for audio recording; Lock mode and Unlock mode. In Lock mode, the sampling frequencies of audio and video are synchronized. In Unlock mode, which the consumer DV format adopts, the two sampling frequencies are independent. The lock mode maintains high compatibility with the higher formats and is more effective than unlock mode in digital processing and smooth transition during audio editing.
- 2) This unit cannot record in DV format with 16 bit - 32 kHz or 44.1 kHz.
- 3) The user bits cannot be set on this unit.

# Compatibility of DVCAM and DV Format

## DVCAM and DV cassettes

Both DVCAM and DV cassettes can be used on DVCAM or DV video equipment. The recording format is defined according to recorder format as described below.

Recorder format	Cassette format	Recording format
DVCAM (If the REC MODE on the VTR SET menu is set to DVCAM on this unit.)	DVCAM DV	DVCAM
DV (If the REC MODE on the VTR SET menu is set to DV SP on this unit.)	DVCAM DV	DV

- This unit can record in DV format. (SP mode only)
- This digital videocassette recorder complies with the DVCAM format. Though DV cassettes can be used for recording, we recommend that you use DVCAM cassettes. Particularly when you use a Mini-DV cassette that is longer than 60 minutes, do not play back the tape repeatedly (i.e., when editing). Set STILL TIME to 1 MIN or 30 SEC (See page 43 ), and FROM REC P to STOP (See page 44 ).
- If you use a DV cassette to record images in the DVCAM format, the recording time will be reduced to 2/3 of the time indicated on the DV cassette.
- If you use a DVCAM cassette to record images in the DV format (SP mode), the recording time will be extended to 1.5 times the time indicated on the DVCAM cassette.

Some tapes cannot be played on DVCAM or DV video equipment.

Tape	On DV video equipment (Consumer VCR)	On DVCAM video equipment (This unit)
DV-formatted	Can be played back. (A tape recorded in the LP mode cannot be played by some equipment.)	Can be played back only when recorded in the SP mode. A tape recorded in the LP mode can be played by some equipment. (This unit can play back a DV-formatted tape only in the SP mode.)
DVCAM-formatted	Some DV video equipment may be able to play back a DVCAM-formatted tape.	Can be played back.



## Compatibility on editing using a DV connection

When this unit is connected to other DVCAM or DV video equipment using DV connectors, the recording format of an edited tape is defined according to the recorder format as described below.

Source tape	Player format	Recorder format <sup>2)</sup>	Recorded format
DV-formatted <sup>1)</sup>	DVCAM	DVCAM DV	DVCAM <sup>3)</sup> DV
DV-formatted	DV	DVCAM DV	DVCAM <sup>3)</sup> DV
DVCAM-formatted <sup>4)</sup>	DVCAM	DVCAM DV	DVCAM DV <sup>6)</sup>
DVCAM-formatted <sup>4)</sup>	DV <sup>5)</sup>	DVCAM DV	DVCAM <sup>7)</sup> DV <sup>6)</sup>

- 1) On this unit, only DV-formatted tapes recorded in the SP mode can be used as source tapes.
- 2) This unit will be restricted according to the REC MODE setting on the **VTR SET** menu.
- 3) When you copy a DV-formatted tape using DVCAM video equipment, the recorded format of the copied tape is the following DVCAM format.
  - The audio recording mode of the copied tape is unlock mode.
  - The time code of the copied tape is partly inaccurate.
- 4) If you use a DVCAM-formatted tape as described in 3) above, the audio recording mode of the recorded tape is unlock mode and the time code is partly inaccurate.
- 5) Some DV video equipment may be able to play back a DVCAM-formatted tape. Even if the tape is played back, the contents of the playback cannot be guaranteed.
- 6) The audio recording mode of the edited tape is lock mode.
- 7) Depending on the signal conditions of the source tape, you may not be able to edit the tape using the DV connection.

## Limitations on editing

You will find the following limitations when editing.

- Due to differences of track pitch, you cannot record or edit DV-formatted tapes using DVCAM video equipment.
- Depending on signal conditions, you may not be able to record or edit DVCAM-formatted tapes. In these cases, copy the tape again using analog audio/video jacks.

# Specifications

## System

Recording format	DVCAM/DV (SP) format, rotating 2-head helical scan, digital component recording
Video signal	EIA STANDARD, NTSC color system CCIR STANDARD, PAL colour system

## Video

Quantification	8-bit
Standardization frequency	NTSC: 13.5 MHz (4:1:1 Component) PAL: 13.5 MHz (4:2:0 Component)

## Audio

Quantification	12-bit (non-linear) or 16-bit (linear)
Standardization frequency	32 kHz (12-bit recording) or 48 kHz (16-bit recording)
Usable cassettes	Standard-DVCAM cassettes <b>and</b> Mini-DVCAM cassettes
Recording time	Standard cassette DVCAM: 184 minutes (PDV184) 180 minutes (DV270) DV: 270 minutes (PDV184/DV270) Mini cassette DVCAM: 40 minutes (PDVM40/DVM60) DV- 60 minutes (PDVM40/DVM60) (We recommend that you use the DVCAM cassettes.)

## Clock

Quartz locked	
Power back-up	Back-up duration: up to one month (after a 10-hour charge)

## Inputs and outputs

Video input	Phono jack Input signal: 1 Vp-p (75 ohms unbalanced)
Video output	Phono jack Output signal: 1 Vp-p (75 ohms unbalanced)
S video input	Mini DIN 4-pin Luminance signal: 1 Vp-p (75 ohms unbalanced) Chrominance signal: 0.286 Vp-p (NTSC) 0.3 Vp-p (PAL) (75 ohms unbalanced)
S video output	Mini DIN 4-pin Luminance signal: 1 Vp-p (75 ohms unbalanced) Chrominance signal: 0.286 Vp-p (NTSC) 0.3 Vp-p (PAL) (75 ohms unbalanced)
Audio input	Phono jack (L,R) Input level: 2 Vrms (full bit) Input impedance: more than 47 kohms
Audio output	Phono jack (L, R) Output level: 2 Vrms (full bit) Output impedance: less than <b>10 kohms</b>
Control S input	Minijack
LANC input/output	Stereo mini-mini jack
DV input/output	4-pin jack

## General

Power consumption	15 W (during playback)
Peak inrush current	Hot switching inrush current, measured in accordance with European standard EN55103-1: 6 A (230V)
Operating temperature	5 °C to 40 °C (41 °F to 104 °F)
Storage temperature	-20 °C to +60 °C (-4 °F to +140 °F)

Dimensions

Approx. 180 x 73 x 265 mm  
(7 1/8 x 2 7/8 x 10 1/2 inches)  
(w/h/d, including projecting parts  
and controls)

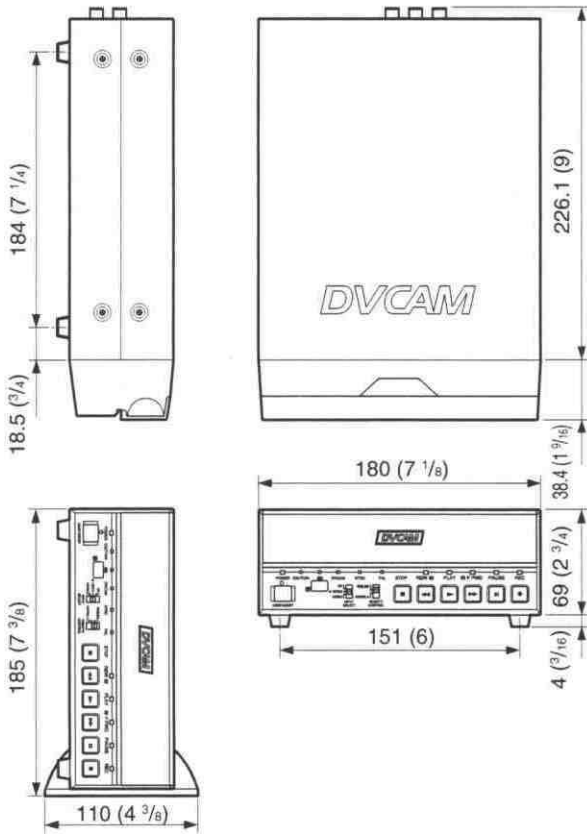

Unit: mm (inches)

Optional accessories

- DSRM-20 Remote Control Unit
- Digital video cassette  
(With cassette memory)  
Standard size: PDV-34ME/  
64ME/94ME/124ME/184ME
- Mini size: PDVM-12ME/22ME/  
32ME/40ME
- (Without cassette memory)**  
**Standard size:** PDV-64N/124N/  
184N
- Mini size:** PDVM-32N/40N

Design and specifications are subject to change  
without notice.

Mass

Approx. 2.7 kg (5 lb 15 oz)

Supplied accessories

- Remote Commander (1)
- Size AA (R6) batteries (2)
- AC power adaptor (1)
- Power cord (1)
- Rack(1)
- Cleaning cassette (1)
- Operating instructions

## Audio recording mode

In the DVCAM format, the sound is recorded in either 16bit (Fs48k) or 12bit (Fs32k) mode.

## Component signal

A video signal consisting of a luminance signal (Y) and two chrominance signals (R-Y,B-Y).

## Condensation

Condensation of moisture on the tape transport mechanisms of VCRs including the head drum. If moisture condenses on the head drum, the tape adheres to the drum and causes malfunction.

## Drop frame mode

In NTSC format, the actual number of frames per second is approximately 29.97, while that for SMPTE time code is specified as 30. Drop frame mode is a mode in which time code is advanced in such a way that the difference in frame value between real time and time code is corrected. In this mode, two frames are skipped at the beginning of each minute, except for every tenth minute, so that the frame value for time code matches that for real time. *See also "Non-drop frame mode."*

## Drum

*See "Head drum."*

## EE mode

EE is an abbreviation of "Electric to Electric." Video and audio signals are supplied to the VCR'S internal circuits, but not to the recording heads.

## Head drum

A metal cylinder to which video heads are attached. During recording and playback, the drum rotates at high speeds in synchronization with the sync signal.

## Loading

When being loaded, the tape is pulled out of the cassette case and threaded along the specified tape path and wrapped round the drum to be ready for recording or playback. Generally, this is done automatically when you place the cassette at the cassette entrance of the VCR. Also called threading.

## Non-drop frame mode

A mode of advancing time code in such a way that the difference in frame value between real time and time code is neglected. Using this mode produces a difference of approximately 86 seconds per day between real time and time code, which may cause problems when editing programs in units of seconds using the number of frames as a reference.

## PCM audio

PCM stands for "pulse code modulation." PCM audio means audio signals that have been processed by pulse code modulation. Each analog audio signal is converted into pulses that are generated in rapid succession, and each pulse is recorded as a digital signal having a value of 0 or 1.

## Search

To locate a particular scene by running the tape in the fast forward or rewind mode while viewing the picture or time codes.

## Superimpose

To put a set of characters onto a picture so that both can be seen at the same time.

## Threading

*See "Loading."*

## Time code

Signals recorded on the tape to supply information on tape position such as the hour, minute, second and frame, to assist in setting edit points or searching for particular scenes. This unit can cope with both DF (Drop Frame) and NDF (Non Drop Frame).

On this unit, the time code is recorded sequentially from "00:00:00:00;" from the beginning of the tape. However, if there is a blank section on the tape, time code is reset and recorded from "00:00:00:00" again from the section just after the blank section. If the time codes are out of sequence, you may not be able to execute correct editing.

## Unloading

When being unloaded, the tape is put into the cassette case from the tape path of the VCR. Generally, this is done automatically when you press the EJECT button. Also called unthreading.

## Unthreading

*See "Unloading."*

## 12bit (Fs32k) mode

In the DVCAM format, the 12bit (Fs32k) mode separates the audio area into 2 parts. You can record two kinds of audio, stereo 1 and stereo 2.

## 16bit (Fs48k) mode

In the DVCAM format, the 16bit (Fs48k) mode uses the whole audio area to record one stereo track. You can get higher sound quality.

# Index

## A, B

AC timer.....	32
Audio mode .27	44
Auto Repeat	32

## C

Camera data.....	25
Cassette memory 16	31
Cleaning.....	52
Clock .....	49

## D, E

Date search .....	29
Drop Frame.....	60
DV	
cassette .....	56
format.....	55
IN/OUT connector .	11
	20 34
DVCAM	
cassette 15	56
format. 6	55

## F, G, H

Fs32k	44
Fs48k	44

## I, J, K

i.LINK .....	11
Index search.....	29

## L

LANCjack ... 11	22	36
Lock mode.....	55	

## M

Menu.....	41
Mini-DVCAM cassette.	15

## N, O

Non Drop Frame,	60
-----------------	----

## P, Q

Photo search .....	29
Playback	
at various speeds .....	28
frame by frame.....	28

## R

Remote Commander.	13
-------------------	----

## S

Searching using search function...	29
Standard DVCAM cassette.....	15

## T

Tape remaining time ... 27	45
Time code .....	49
Title search .....	29

## U, V, W, X, Y, Z

Unlock mode .....	55
Usable cassette .....	15